

Defense and Government Procurement
Complete Shelter Solutions



Shasta Shelter[®]
Installation World Wide



Design . Engineering . Manufacturer . Sales . Service

Shasta Shelter[®] - FTS20, FTS50, FTS100, FTS150, FTS200



Our Vision

Creative Tent International is committed to the success of your mission



Portable Structures Worldwide

Clear Span
Engineered - All Weather Conditions
Portable / Re-locatable
Service Worldwide
Light Weight
Small Shipping Cube
Quick Installation
Temporary / Permanent
Complete Accessories

Manufacturing capability of 250,000 sq ft per month.
We ship and provide turnkey installation anywhere.
Turnkey 500 - 5000 Person Camps with complete accessories.
We have a network of representatives to provide ongoing services after installation.



Our Mission

We uphold the customer and the product.



Creative Tent International, Inc. has products in more than 60 countries used by the military and government, industrial, hospitality, rental, and sports and recreation industries.



- Mission Essentials
- Morale, Welfare & Recreation
- Billeting
- Dining Hall

- Aircraft Maintenance Shelter
- Vehicle Maintenance Shelter
- Large Area Maintenance Shelters
- Medium Area Maintenance Shelters
- Dehumidified Units

Shasta Shelter[®] Specifications

CTI specifications are as follows: The structure is a clear span, frame-supported tension fabric structure of modular design with open, gable or round ends with accessories of: personnel doors, vehicle doors, fabric doors, electrical lighting systems, tool kits, ventilation (HVAC, dehumidifiers, vents), liners (insulating or decorative), and floor systems. See CTI accessories for full choice on each unit.

There are no internal posts or supports. The structure is a pre-engineered unit requiring no on-site fabrication or welding to install or relocate. This applies to structural frame components, fabric and accessories. The structure is fully relocatable, allowing for disassembly and reuse of all components (except anchors) without additional fabrication or welding of structural components or fabric. Product specific specifications are detailed in each category.

Frame Specs: Frame consists of a series of identical arches, with connecting purlins and cables. The arches have rounded eaves and ridge with snap button connections. Frame components for the arches are a hollow oval-beam design made from extruded corrosion-resistant, anodized, lightweight 6061-T6 structural grade aluminum. The extrusion for the arches has integral inner and outer rope edge channels to accommodate exterior (fabric shell) and interior (liner) tensioned fabric panels. The extrusion is designed to allow rapid attachment or relocation of lighting, rigging and other accessories without drilling or welding.

Interchangeability/Modularity: Structural components are such that like components can be exchanged within or between like structures. Purlins and shear cables are located on the inside of the fabric shell. Base plates are anchored prior to frame installation for safety reasons. Arches are assembled on the ground and tilted up to position after attachment to base plates utilizing a hinge-pin design. All structural fasteners are galvanized steel ASTM A325. Anchor bolts conform to ASTM A325 or ASTM A193, grade B7. Tech screws and other non-structural attachments are of standard commercial quality and finish. Structures are capable of being equipped with an optional high-wind kit for increased wind loading. Snow-load kits can also be added for increased snow loading in extreme conditions, which does not require welding or drilling into the frame.

Fabric Specs: Fabric shell is flame resistant (as defined under NFPA 701. (Laminate or Coated) PVC material weighing at least 18oz. per linear yd² and strong enough to meet the performance characteristics required of the structure. The fabric shell standard for commercial structures is a white (color) exterior and white (color) interior. Optional is an opaque (translucent or opaque w/ skylight). The fabric shell standard for military structures is a tan (color) exterior and white (color) interior. Fabric panels for each bay of the structure are designed so that installation and removal can be accomplished with all personnel on the ground. The fabric panels are integrated with the frame during installation so that unexpected winds during installation cannot sail the fabric away from the frame. To allow for relocation of the structure after the initial installation fabric or heat-sealing are not be permitted during installation. Fabric shell panels and optional inner liner fabric panels are capable of being installed, replaced or removed individually with the structure erected and operational.

Engineering Specs: The structure is designed for constant winds of 90 mph with a utility load of 2 pounds per square foot (psf) per International Building Code (IBC). Optional high-wind kit increases wind loading to 120+ mph and snow load kit increases snow loading to 30+ psf ground snow load.

Anchoring Specs: The structure is designed for installation on a dirt, grass, or asphalt surface using stakes 1" x 40" and duckbill (88) type anchors. For concrete surfaces expansion-style anchors are used. The number, size and strength of the anchors are adequate for the wind and roof load requirements. One set of anchors for concrete is included.

20' width x 32' length
7' Eave (12' Peak) x 16' Bay Spacing, 2 Gable Ends

Shasta Shelter[®] FTS20

Includes:

- 2 - Zipper Doors - (4' x 6'-8")
- 1 - Electrical System - Re-locatable 60 Hz /240 V/3 Phase Electrical System Distribution Panel
- (4) 60 W Lights
- (4) 125V Duplex Receptacles
- 2 - HVAC Duct Sets (Adjustable up to 20" Diameter)
- HVAC 5 Ton Commercial Unit Skid Mount w/Duct
- Liner 20'x32' with Fabric Floor
- 10 - Windows, (Flap, Clear, Mesh)
- 1 - Concrete and Ground/Asphalt Anchor Sets
- Floor System Plastic 8000psf
- 1 - FTS20 Installation Kit

Shelter Weight - 2,320 lbs.
4 units per 20' Container

Other Accessories Available:

HVAC Systems, Floor Systems, Personnel Doors (Flow Through or Latch Lock, Fabric Sliding Doors), and More

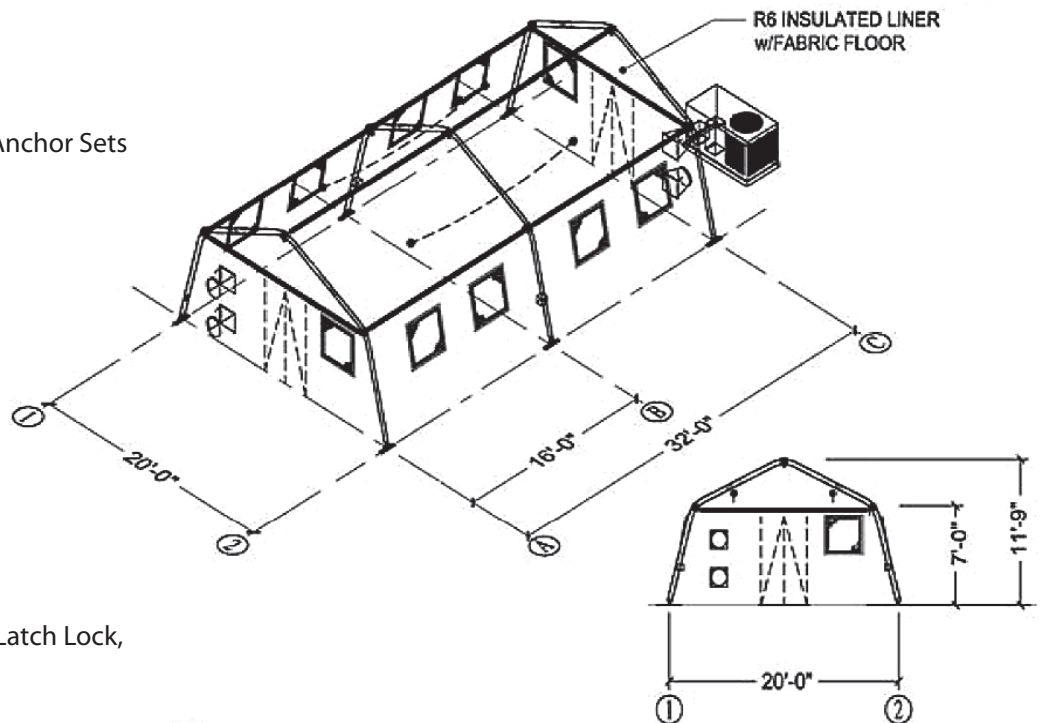

30' width x 60' length
8' Eave (14' Peak) x 20' Bay Spacing, 2 Gable Ends

Shasta Shelter® FTS20

Includes:

- 2 - Zipper Doors - (4' x 6'-8")
- 1 - Personnel Double Door
(6'w x 6' 8"h)
- 1 - Zipper Doors - (4' x 6'-8")
- 1 - Electrical System - Re-locatable 60
Hz /240 V/3 Phase Electrical System
Distribution Panel
- (8) 60 W Lights
- (8) 125V Duplex Receptacles
- 2 - HVAC Duct Sets (Adjustable
up to 20" Diameter)
- 12 - Windows, (Flap, Clear, Mesh)
- 1 - Concrete and Ground/Asphalt
- 1 - FTS20 installation Kit

Shelter Weight -1,280 lbs.
10 per-20' Containers

Other Accessories Available:

HVAC Systems, Liners, Floor Systems, Single
or Double, Personnel Doors, Turn-Key
Installation and More

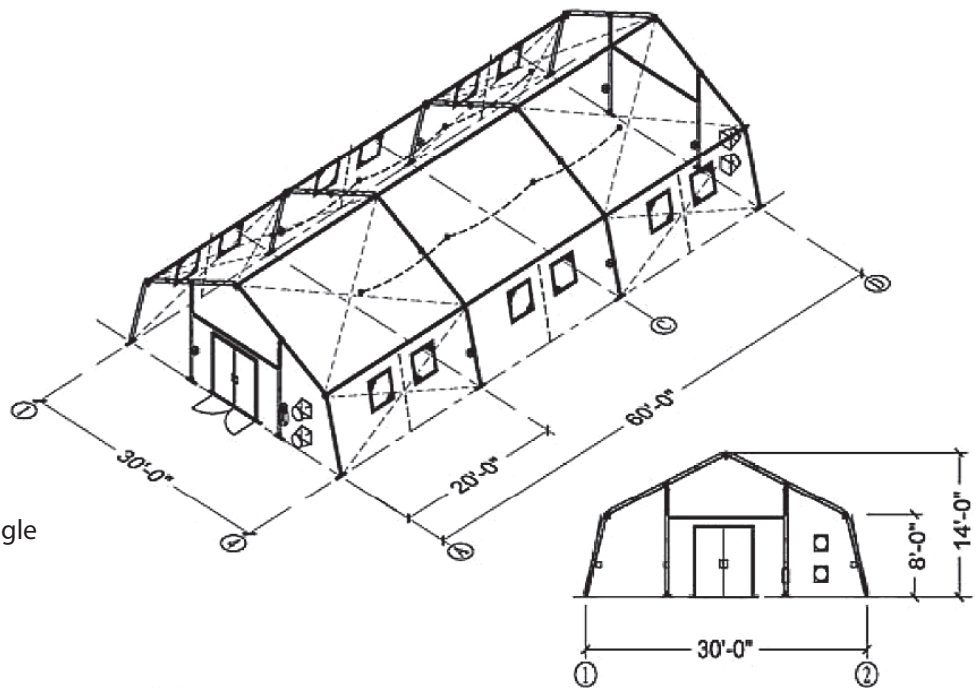

40' width x 120' length
7' Eave (16' Peak) x, 20' Spacing, 2 Gable Ends

Shasta Shelter® FTS20

Includes:

- 2 - Double Doors - (6' x 6'-8")
- 1 - Electrical System - Re-locatable 60 Hz /240 V/3 Phase Electrical System Distribution Panel
- Lights
- 2 - HVAC Duct Sets (Adjustable up to 20" Diameter)
- 24 - Windows, (Flap, Clear, Mesh)
- Concrete and Ground/Asphalt Anchors
- 1 - FTS20 Installation Kit



Shelter Weight - 4,317 lbs.
Ship Cube – 2 units per 20' Container

Other Accessories Available:

- Zipper Doors - (4' x 6'-8")
- HVAC Systems
- Liner, Floor Systems

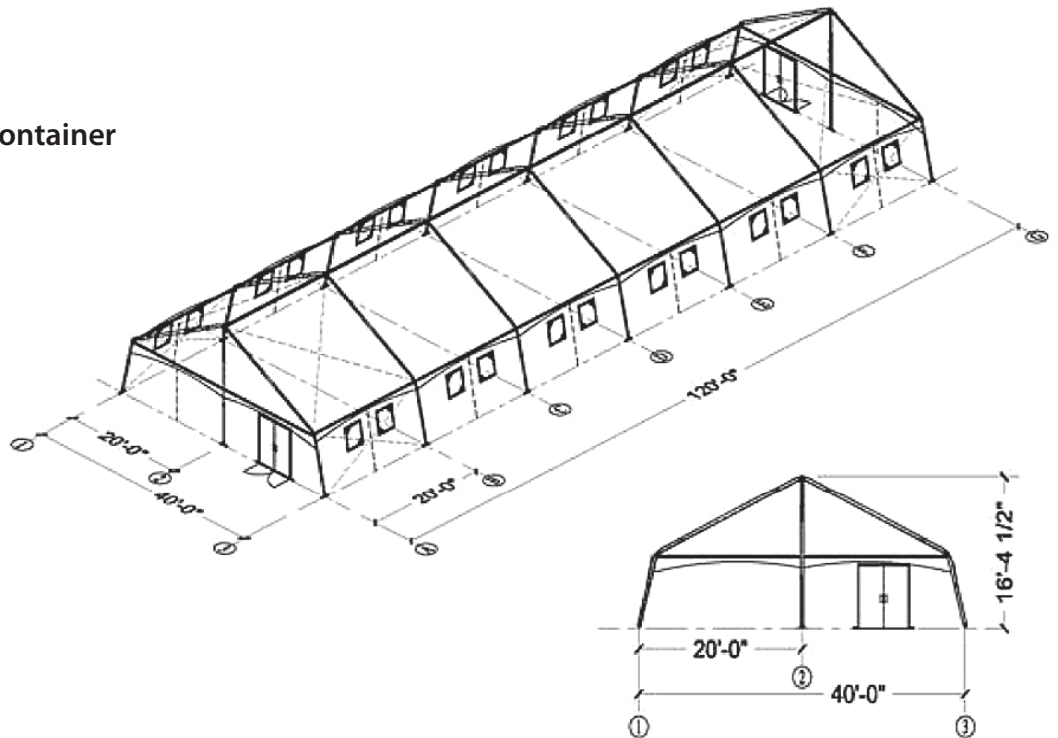

30' width x 44' length
12' Eave (17' 1" Peak) x 12' 6" Bay Spacing, 1 Gable End, 1 Full Width Door

Shasta Shelter[®] FTS50

Includes:

- 1 - Single Personnel Door – Equipped with Lockable Exit Hardware (3' x 6' 8")
- 1 - Electrical System – Re-locatable 60Hz / 240 V/3 Phase Electrical System Distribution Panel
- (2) Indirect LED Lights
- (2) Duplex Receptacle Switch Box (120 Volt/60 Hertz)
- 2 - HVAC Duct Sets (Adjustable up to 20" Diameter)
- 1 - Concrete and Asphalt Anchor Set
- 1 - FTS50 Installation Kit



Shelter Weight 5919 lbs.
Cube 1 – 20' Containers

Other Accessories Available:

HVAC Systems, Liners, (Metal Roll-Up Doors), Floor Systems, Turn-Key Installation and More

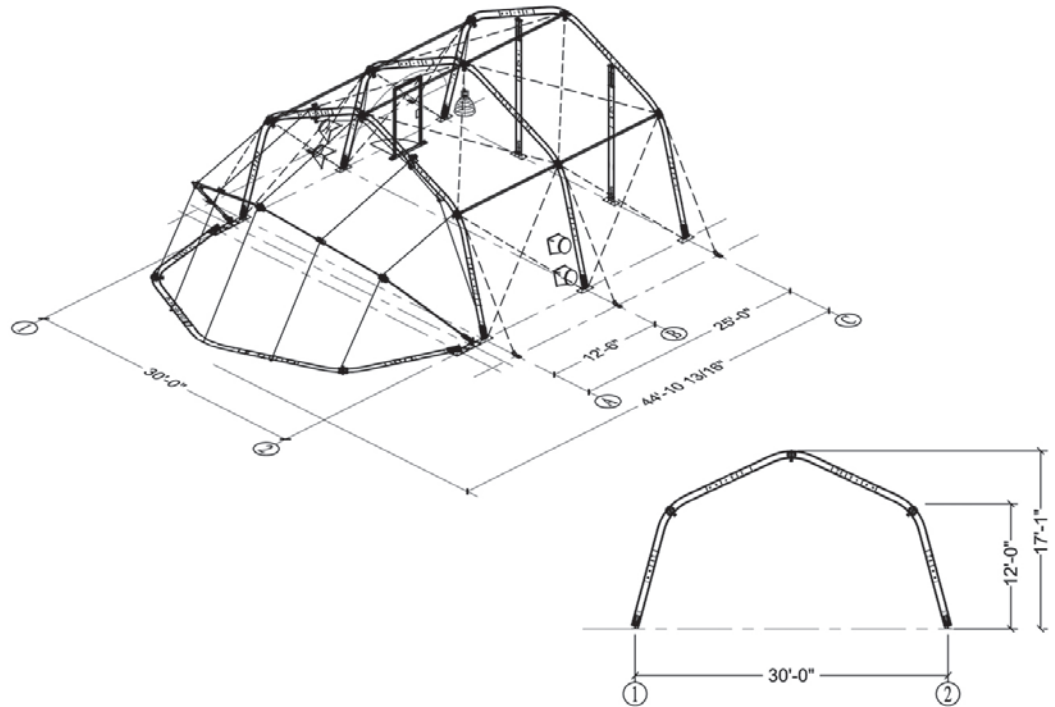

47' width x 50' length
14' Eave (23' Peak) x 12'- 6" Bay Spacing, 2-Gable Ends

Shasta Shelter® FTS50

Includes:

1 - Single Personnel Door - Equipped with Lockable Exit Hardware (3' x 6'-8")

1 - Double Personnel Doors (Flow Through or Latch Lock) (6'0"wx6'8"h)

2 - Fabric Sliding Door 14' High - Allows Large Vehicle Access Into the Interior

1 - Electrical System - Re-locatable 60 Hz /240 V/3 Phase Electrical System Distribution Pane

(3) Indirect LED Lights

(3) 20A 125V Duplex Receptacles

2 - HVAC Duct Sets (Adjustable up to 20" Diameter)

1 - Concrete and Ground/Asphalt Anchor Sets

1 - FTS50 Installation Kit

Shelter Weight 5,598 lbs.

Cube 2 units per 20' Containers

Other Accessories Available:

HVAC Systems, Liners, (Metal Roll-Up Doors), Floor Systems, Turn-Key Installation and More

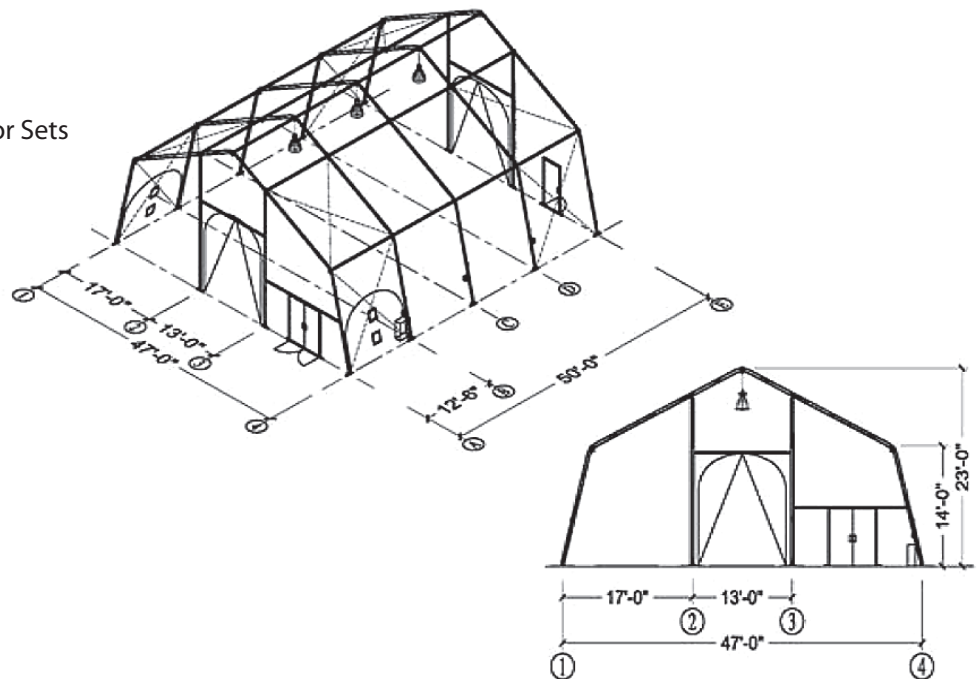

47' width x 100' length
14' Eave (23' Peak) x 12'- 6" Bay Spacing, 2 Gable Ends

Shasta Shelter® FTS50

Includes:

2 - Double Personnel Doors - Equipped with Lockable Exit Hardware (3' x 6'-8")

1 - Electrical System - Re-locatable 60 Hz /240 V/3 Phase Electrical System Distribution Panel

(10) Indirect LED Lights

(12) 20A 125V Duplex Receptacles

2 - Metal Roll-Up - Manual (15'wX10';15';20'h)

1 - Concrete and Ground/Asphalt Anchor Sets

1 - FTS50 Installation Kit

**Shelter Weight 10,798 lbs.
1 unit per 20' Container**

Other Accessories Available:

HVAC Systems, Insulation Liners, Floor Systems, Turn-Key Installation and More

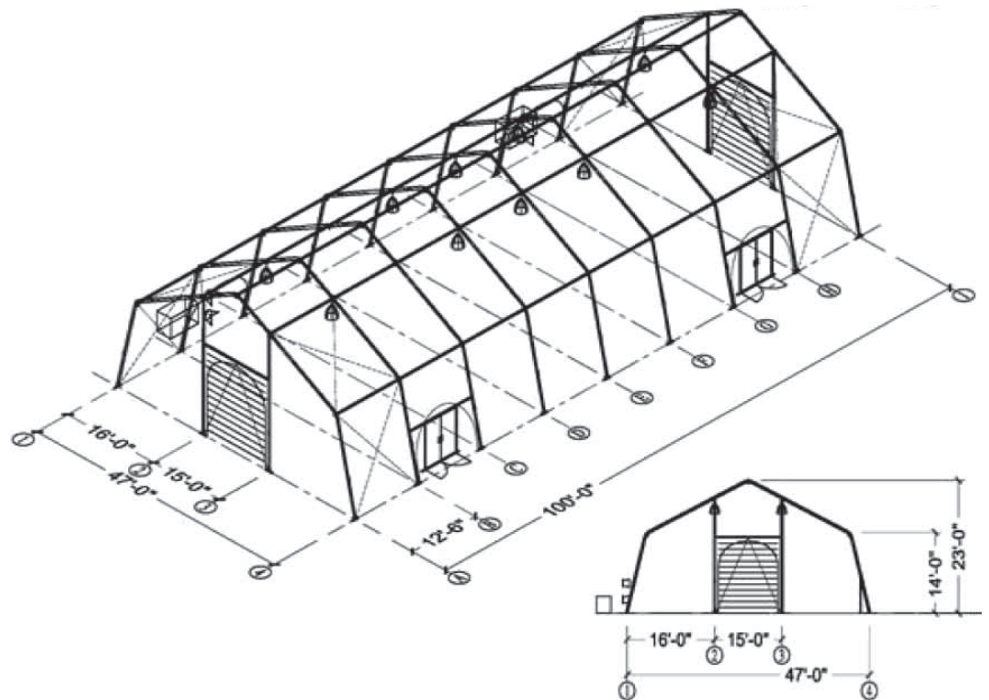

47' width x 113' length
14' Eave (23' Peak) x 12'-6" Bay Spacing, 2- Full Width Doors

Shasta Shelter[®] FTS50

Includes:

2 - Single Personnel Doors - Equipped with Lockable Exit Hardware (3' x 6'-8")

2 - Full Width Doors - Entire End Draws Up to Open or Down to Close Electrically for Full Width Access into the Interior

1 - Electrical System - Re-locatable 60 Hz /240 V/3 Phase Electrical System Distribution Panel

(4) Indirect LED Lights

(6) 20A 125V Duplex Receptacles

2- HVAC Duct Sets (Adjustable up to 20" Diameter)

1 - Concrete and Ground/Asphalt Anchor Sets

1 - FTS50 Installation Kit

Shelter Weight 10,272 lbs.
Cube 1-20' Container

Other Accessories Available:

HVAC Systems, Liners, (Metal Roll-Up Doors), Floor Systems, Fabric, Sliding Doors, Turn-Key Installation and More

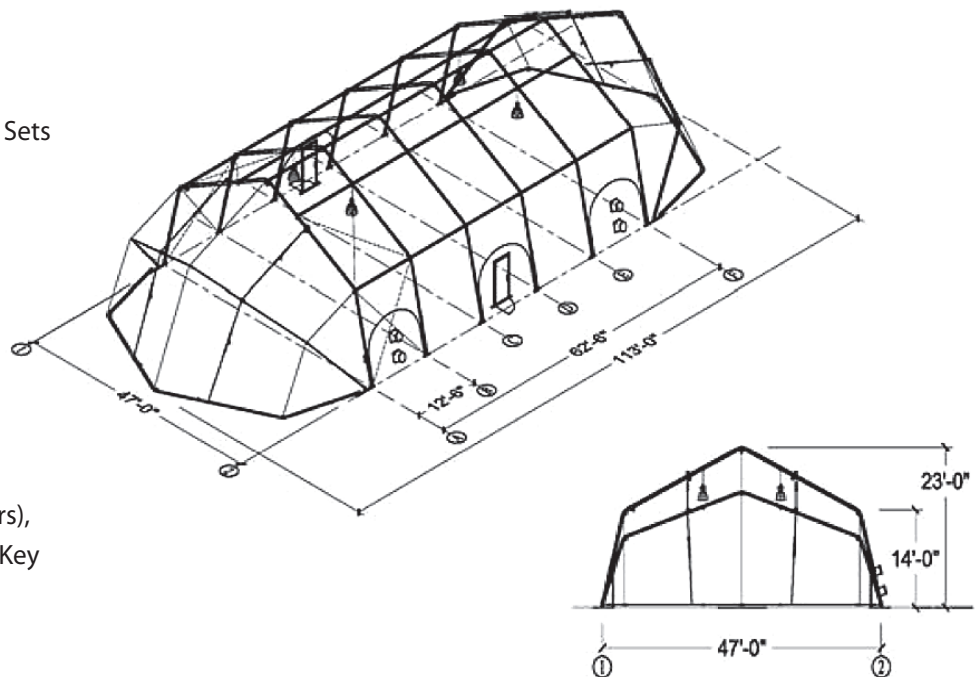

50' width x 100' length
14' Eave (23' Peak) x 20' Bay Spacing, 2 Gable Ends

Shasta Shelter® FTS100

Includes:

- 2 - Single Personnel Door – Equipped with Lockable Exit Hardware (3' x 6' 8")
- 2 - Metal Roll-Up Doors 12' x 12' (Side or End)
- 1 - Electrical System – Re-locatable 60Hz / 240 V/3 Phase Electrical System Distribution Panel
- (8) Indirect LED Lights
- (8) Duplex Receptacle Switch Box (120 Volt/60 Hertz)
- 4 - HVAC Duct Sets (Adjustable up to 20" Diameter)
- 1 - Concrete and Asphalt Anchor Set
- 1 - FTS100 Installation Kit

Shelter Weight 18500 lbs.
Cube 2 – 20' Containers

Other Accessories Available:

HVAC Systems, Liners, Floor Systems,
Turn-Key Installation and More

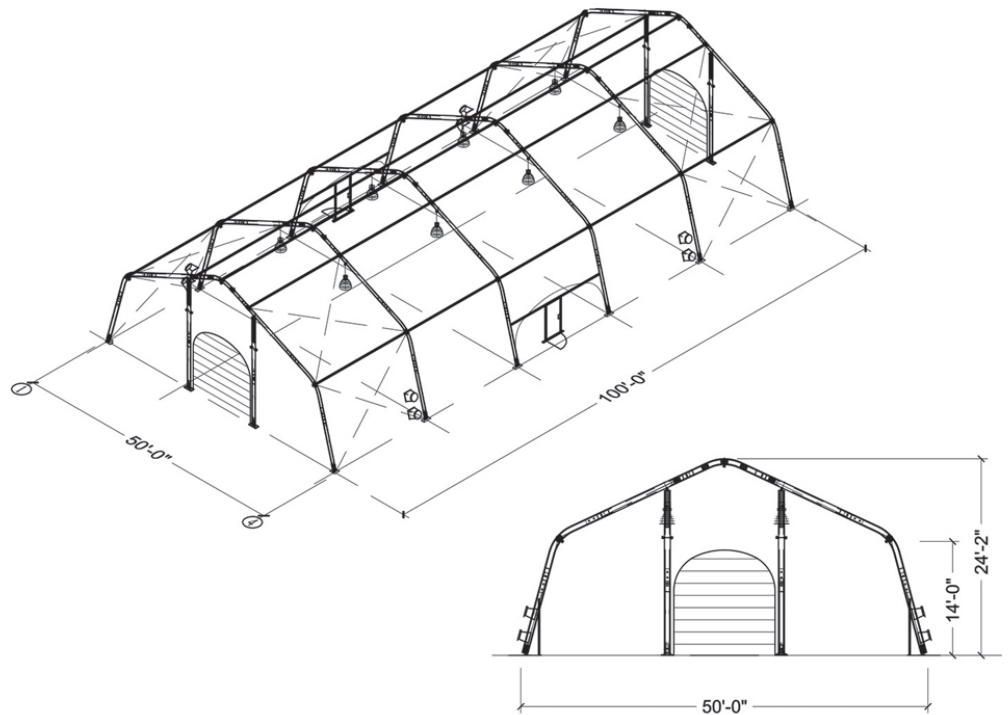

65' width x 80' length
16' Eave (29' Peak) x 16' Bay Spacing, Open Ends

Shasta Shelter® FTS100

Includes:

- 1 - Electrical/Lighting System
- (8) Indirect LED Lights
- (8) 120 VAC Single Gang Receptacles
- (1) Distributions Panel
- 1 - FTS100 Installation Kit

Shelter Weight 6,800 lbs.
Cube 1 units per 20' Containers



Other Accessories Available:

Gable Ends, Full Width Doors,
Side Vehicle Access Doors, HVAC
Systems, Liners, Floor Systems,
Electric Ventilator Fans,
Wall Panels, and More

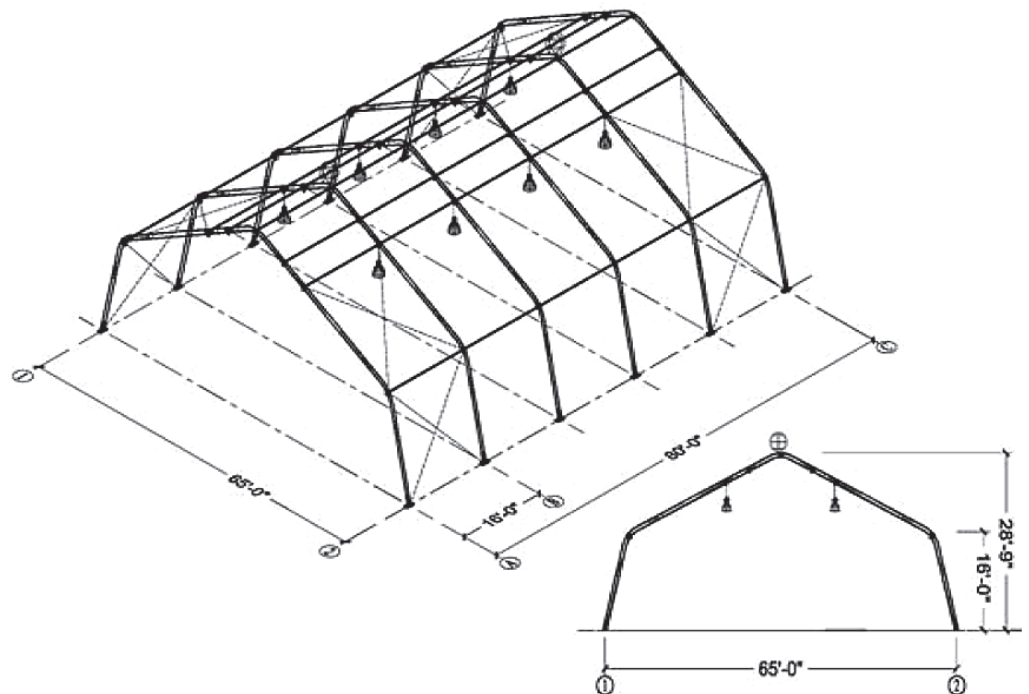

65' width x 105' length
16' Eave (29' Peak) x 15' Bay Spacing, 2-Gable Ends

Shasta Shelter® FTS100

Includes:

2 - Double Personnel Doors - Equipped with Lockable Exit Hardware (6'0w x 6'8"h)

2 - Gable Ends

2 - Metal Roll-Up Doors 15' x 14' (Side or End)

1 - Electrical System - Re-locatable 60 Hz /240 V/3 Phase Electrical System Distribution Panel

(10) Indirect LED Lights

(12) 20A 125V Duplex Receptacles

2 - HVAC Duct Sets (Adjustable up to 20" Diameter)

1 - Concrete and Ground/Asphalt Anchor Sets

1 - FTS100 Installation Kit

Shelter Weight 16,080 lbs.
Cube 2-20' Containers

Other Accessories Available:

HVAC Systems, Liners, Floor Systems, Electric Ventilator Fans, Installation Kit, Turn-Key Installation and More

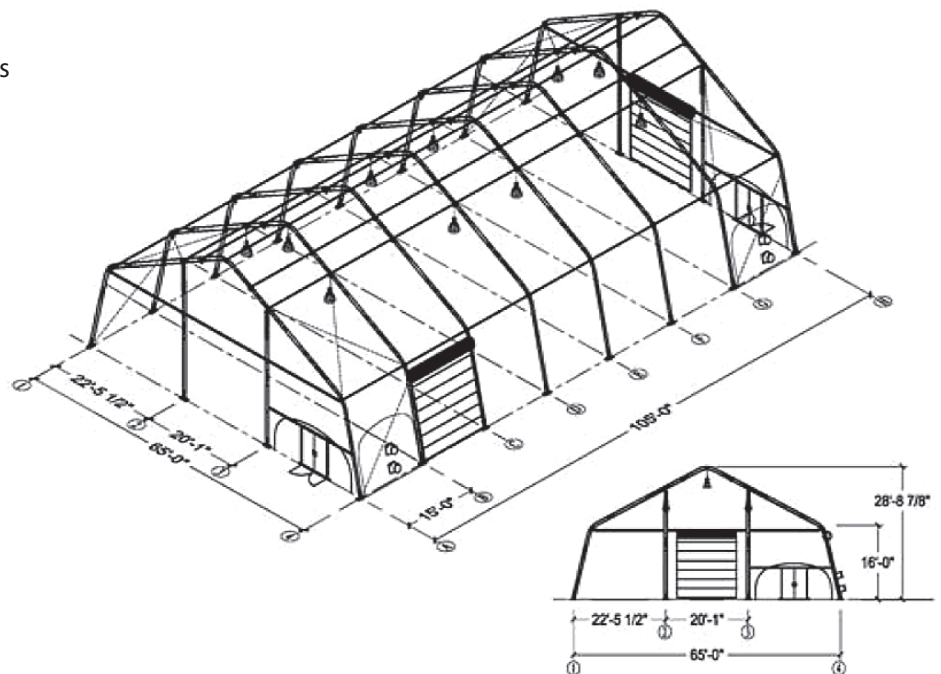

75' width x 128' length LAMS-V
16' Eave (32' Peak) x 12.5' Bay Spacing, 2-Full Width Doors

Shasta Shelter[®] FTS100

Includes:

- 2 - Single Personnel Doors - Equipped with Lockable Exit Hardware (3' x 6'-8")
- 2 - Full Width Doors - Entire End Draws Up to Open or Down to Close Electrically for Full Width Access into the Interior
- 1 - Electrical System - Re-locatable 60 Hz /240 V/3 Phase Electrical System Distribution Panel
- (10) Indirect LED Lights
- (12) 20A 125V Duplex Receptacles
- 2 - Fabric Sliding Door (12.5'wX16'h) Side
- 2 - HVAC Duct Sets (Adjustable up to 20" Diameter)
- 1 - Concrete and Ground/Asphalt Anchor Sets
- 1 - FTS100 Installation Kit

Shelter Weight 21,500 bls.
Cube 2-20' Containers

Other Accessories Available:

HVAC System, Liners, Roll-Up Doors, Floor Systems, Electric Ventilator Fans, Turn-Key Installation and More

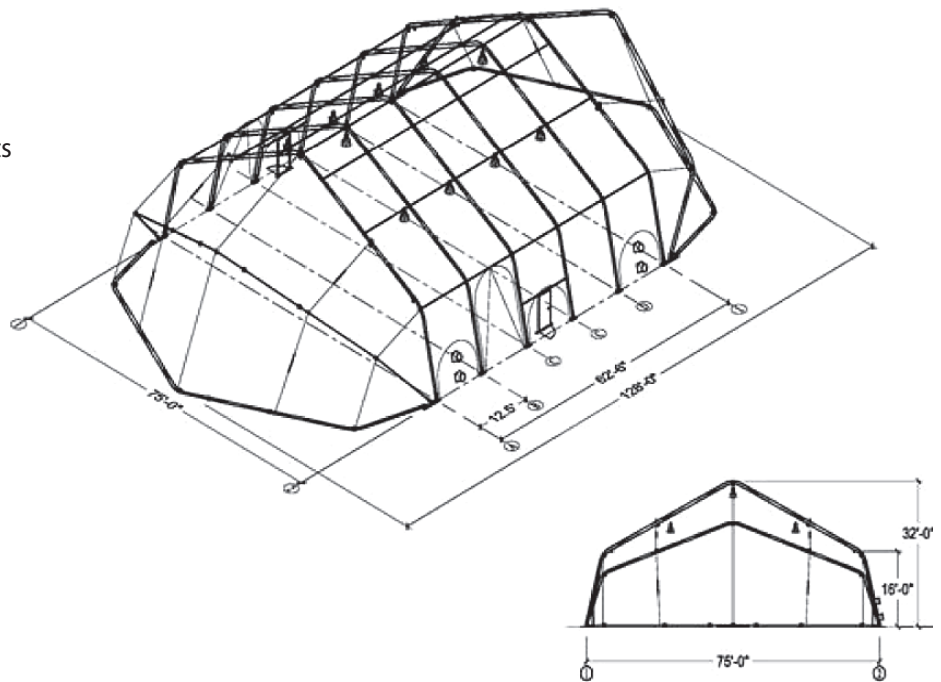

LAMS-V WITH METAL ROLL-UP DOORS --- NSN# 5410-01-610-8773

LAMS-V WITH FABRIC SLIDING DOOR --- NSN# 5410-01-611-2401

75' width x 191' length LAMS-A
16' Eave (32' Peak) x 12.5' Bay Spacing, 2-Full Width Doors

Shasta Shelter® FTS100

Includes:

2 - Single Personnel Doors - Equipped with Lockable Exit Hardware (3' x 6'-8")

2 - Full Width Doors - Entire End Draws Up to Open or Down to Close Electrically for Full Width Access into the Interior

1 - Electrical System - Re-locatable 60 Hz /240 V/3 Phase Electrical System Distribution Panel

(10) Indirect LED Lights

(12) 20A 125V Duplex Receptacles

2 - HVAC Duct Sets (Adjustable up to 20" Diameter)

1 - Concrete and Ground/Asphalt Anchor Sets

1 - FTS100 Installation Kit

**Shelter Weight 25,500 lbs.
Cube 3-20' Containers**

Other Accessories Available:

HVAC Systems, Liners, Floor Systems, Electric Ventilator Fans Roll-Up Doors, Fabric Sliding Door, Turn-Key Installation and More

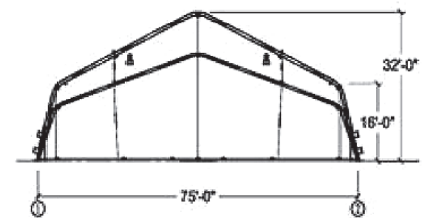
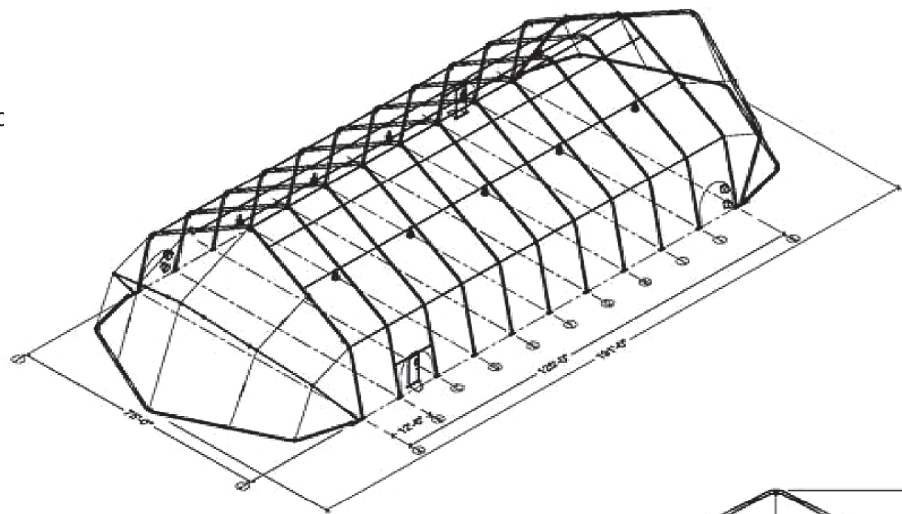

LAMS-A WITH FABRIC SLIDING DOOR --- NSN# 5410-01-612-8219

90' width x 125' length
16' Eave (36' Peak) x 16' Bay Spacing, 1-Full Width Door, 1-Gable End

Shasta Shelter® FTS150

Includes:

2 - Single Personnel Doors - Equipped with Lockable Exit Hardware (3' x 7')

1 - Full Width Doors - Entire end Draws up to Open or Down to Close Electrically for Full Width Access into the Interior

1 - Electrical System - Re-locatable 60 Hz/110 Electrical System, Distribution Panel

(10) Indirect LED Lightss

(12) 20A 125V Duplex Receptacles.

1 - Metal Roll-Up Doors (15'w x 14'h) End or Side

2 - HVAC Duct Sets (Adjustable up to 20" Diameter)

1 - Concrete and Ground/Asphalt Anchor Sets

1 - FTS150 Installation Kit

**Shelter Weight 25,500 lbs.
Cube 3-20' Containers**

Other Accessories Available:

HVAC Systems, Liners, Floor Systems,
Electrical Grounding Kit, Ventilation Kit,
Turn-Key Installation and More

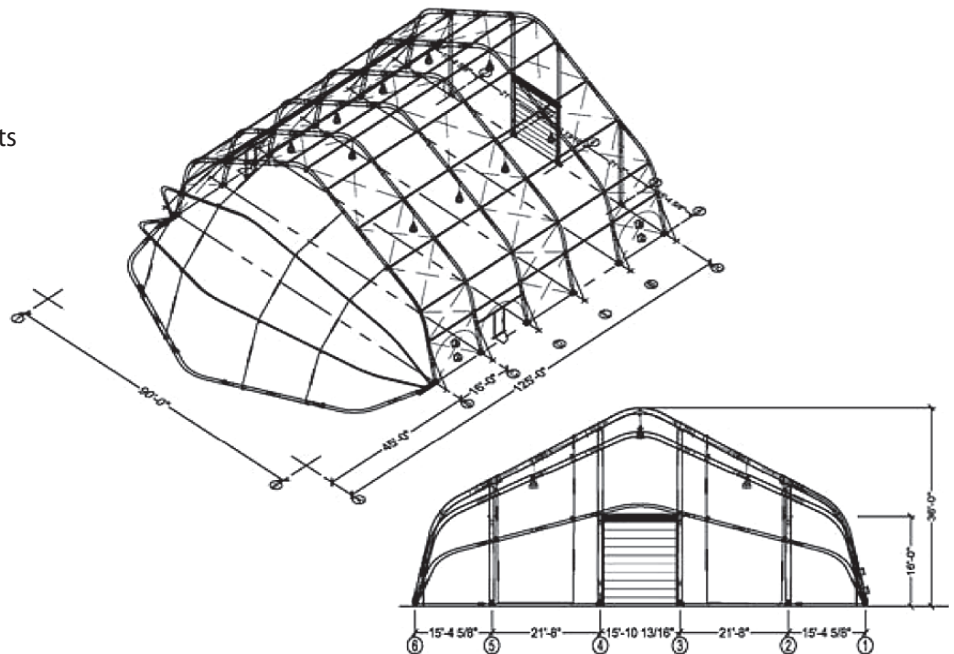

90' width x 157' length
16' Eave (36' Peak) x 16' Bay Spacing, 1-Full Width Door, 1-Gable End

Shasta Shelter® FTS150

Includes:

- 2 - Single Personnel Doors - Equipped with Lockable Exit Hardware (3' x 7')
- 1 - Full Width Door with Winch.
- 1 - Gable End Kit
- 1 - Electrical System - Re-locatable 60 Hz/110 Electrical System, Distribution Panel with a Main Breaker and Individual Circuit Breakers (9) High Pressure
- (9) Indirect LED Lights
- (10) 110-Volt Duplex Outlets
- 1 - Metal Roll-Up Door (15' x 12') on Gable End
- 2 - HVAC Duct Sets (Adjustable up to 20" Diameter)
- 2 - Electrical Ventilators
- 1 - Concrete and Ground/Asphalt Anchor Sets
- 1 - Electrical Grounding Kit
- 1 - FTS150 Installation Kit

Shelter Weight 43,185 lbs.
Cube 3-20' Containers

Other Accessories Available:

HVAC Systems, Liners, Floor Systems, Electrical Grounding Kit, Ventilation Kit, Turn-Key Installation and More

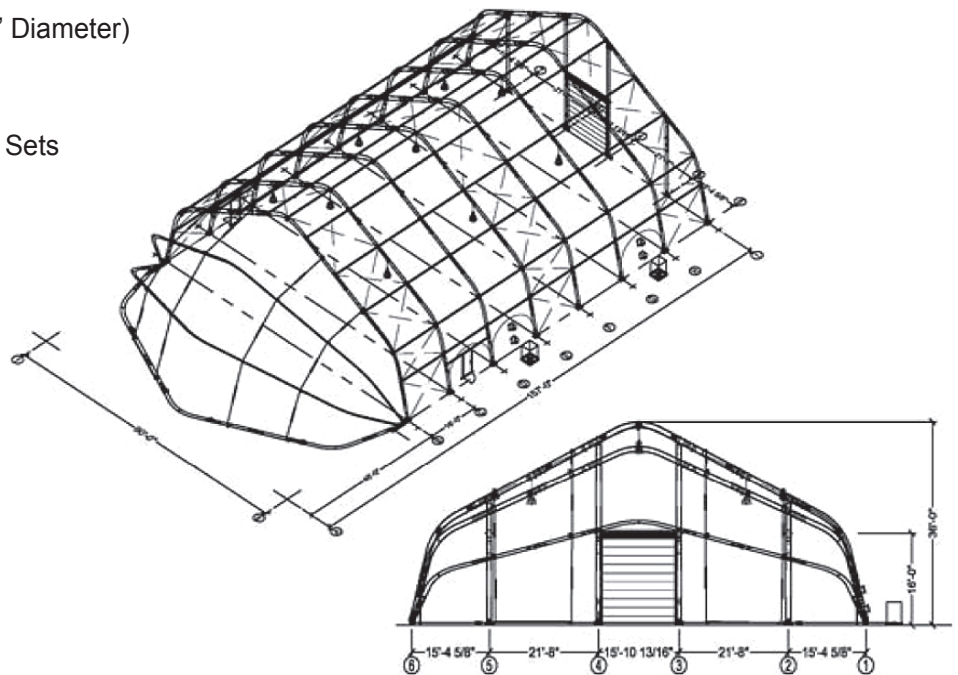

105' width x 265' length
16' Eave (39' Peak) x 15' Bay Spacing, 2-Full Width Doors

Shasta Shelter® FTS150

Includes:

4 - Single Personnel Doors - Equipped with Lockable Exit Hardware (3' x 6'-8")

1 - Full Width Doors - Entire end Draws up to Open or Down to Close Electrically for Full Width Access into the Interior

2 - Electrical System - Re-locatable 60 Hz /240 V/3 Phase Electrical System
(2) Distribution Panels

(20) Indirect LED Lights

(24) 20A 125V Duplex Receptacles.

6 - HVAC Duct Sets (Adjustable up to 20" Diameter)

1 - Concrete and Ground/Asphalt Ancho Sets

1 - FTS150 Installation Kit

Shelter Weight 69,250 lbs.
Cube 5-20' Containers

Other Accessories Available:

HVAC Systems, Liners, Floor Systems,
Electric Ventilator Fans, Roll-Up Doors,
Turn-Key Installation and More

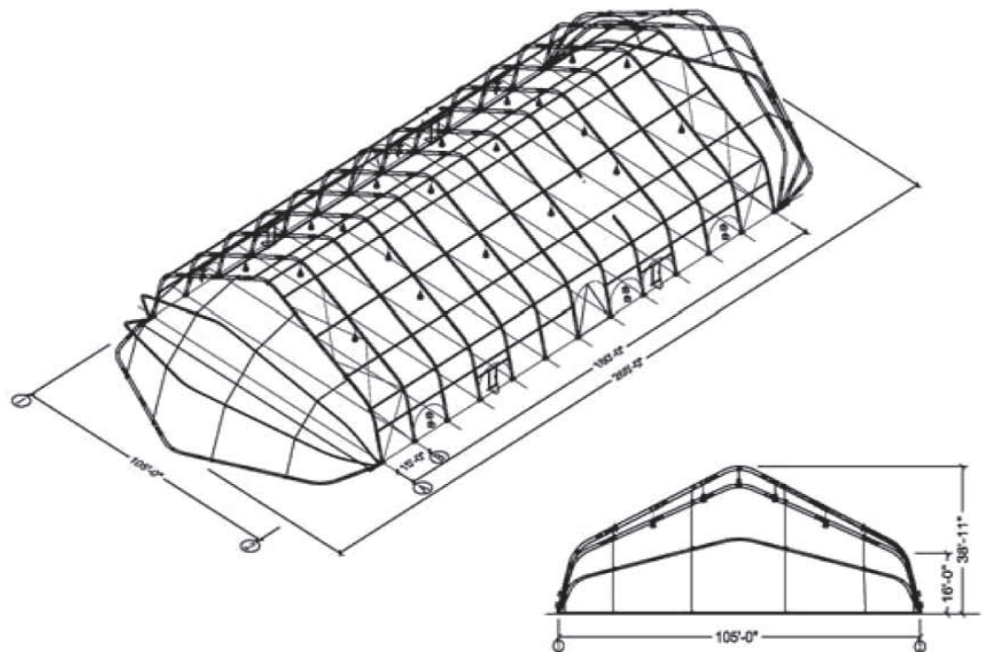

105' width x 265' length
24' Eave (46' Peak) x 15' Bay Spacing, 2-Full Width Doors

Shasta Shelter® FTS150

Includes:

2 - Single Personnel Doors - Equipped with Lockable Exit Hardware (3' x 6'-8")

2 - Full Width Doors - Entire end Draws up to Open or Down to Close Electrically for Full Width Access into the Interior

2 - Metal Roll-Up Doors (manual) (15W x 14H)

2 - Electrical System - Re-locatable 60

Hz /240 V/3 Phase Electrical System

(1) Distribution Panel

(20) Indirect LED Lights

(20) 20A 125V Duplex Receptacles

(12) Circuits

1 - Concrete and Ground/Asphalt Anchor Sets

1 - FTS150 Installation Kit

Shelter Weight 72,250 lbs.

Cube 5-20' Containers

Other Accessories Available:

HVAC Systems, Liners, Floor Systems,

Electric Ventilator Fans, Turn-Key

Installation and More

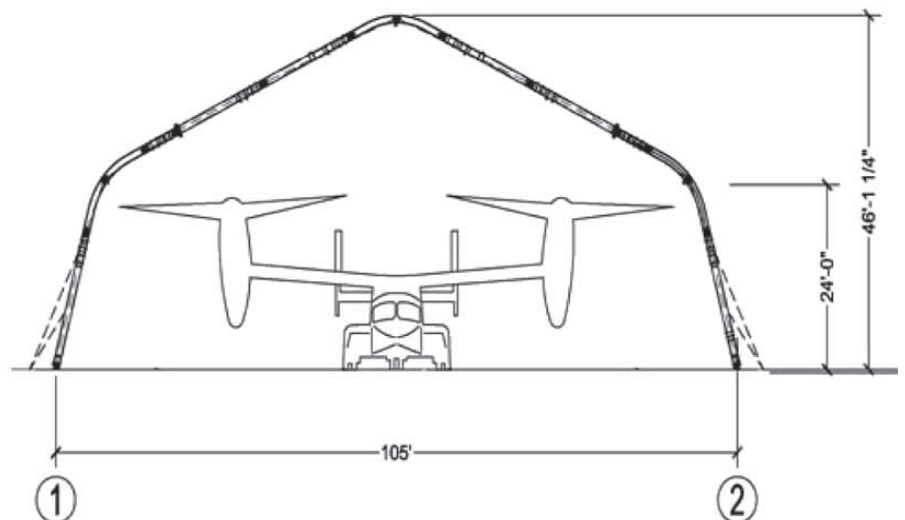

Configurations:

- Open Ends
- Gable Ends
- Round Ends
- Full Width Doors



ACCESSORIES & OPTIONS

Doors and Access:

- Single and Double - Personnel Doors
- Composite Steel Doors
- Full Width Doors
- Fabric Sliding Doors
- Roll-Up Doors



Electrical & Lighting Packages - Plug & Play Systems:

- 50 Hrzs or 60 Hrzs - Panel Boards, Lights w/ Cords and Electrical Outlets, LED or Metal Halides, Safety Kits

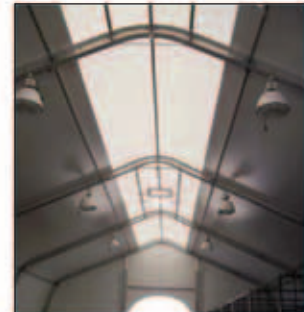

Ventilation:

- Fabric Ventilation, Wind Driven Ventilation
- Electric Ventilation
- HVAC – 5 ton, 10 ton, 20 ton Systems with Ducting
- Wall Duct Sets
- Interior Ducting

Liners:

- Insulating Liners - R6 or R16
- Decreases HVAC Requirements as Much as 40%

Window and Wall Options:

- Mesh Windows with Cover Flaps

Flooring Systems:

- Plastic Modular 36,000 psf
- Plastic Modular 80,000 psf
- Plywood/Lumber/Carpet
- Fabric Moisture Barrier

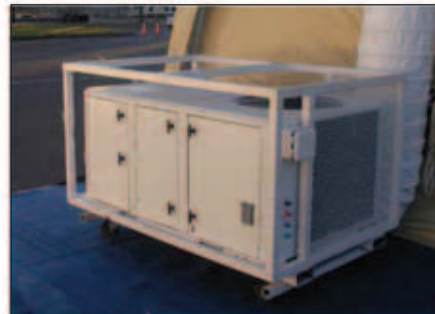

Skylight

Tool Kits

Dehumidification Systems

Containers

Generators

Solar Packages



service@creativetent.us Toll Free 888-484-8368
www.creativetent.us

GSA Service & Maintenance Contract

GSA Contract No. GS04Q14DBD0002

Key Advantages

CTI is the contract holder for the GSA fabric shelter contract sponsored by the US Army TACOM division.

Contract scope includes repair, maintenance, installation and disassembly services, inspections and consultation relating to all fabric shelters, systems and tents.

Contract is usable by all divisions of the US Military, DoD, and Federal Agencies.

Worldwide capability (CONUS and OCONUS).

Quick and easy contracting support with GSA.

High security access, cleared and experienced personnel.



Basic Process

- Determine if service requirement falls under the contract scope.
- Initial budgetary estimate issued by CTI.
- TACOM Natick generates official scope of work.
- Customer's funds are sent to GSA.
- Task order issued to CTI.





Shasta Shelter®

Defense and Government Procurement

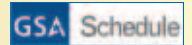

Creative Tent International, Inc. is dynamic and responsive to your mission. Over 50 years of experience in design, manufacturing and service to the fabric structure industry. We stand behind our products - 100%. We are field sensitive to onsite environmental conditions, complexity of installation and logistics.

Made in the USA • Designed, Engineered and Manufactured for Superior Quality



Creative Tent International, Inc.

451 Mirror Court, Ste. 101

Henderson, NV 89011

+1 702-789-2620 • Toll Free 888-848-8368 • sales@creativetent.us

