

BANAIR
MILITARY STORAGE / WAREHOUSE SOLUTIONS

WWW.BAN-AIR.COM
SALES@BAN-AIR.COM





WHAT IS BANAIR?

European Based Designer, Manufacturer and Installer of innovative engineered logistical solutions for US military clients worldwide.

BANAIR CORE COMPETENCY

- Warehouse and SSA Space Optimization
- Container and Heavy Bulk Equipment Storage
- Expeditionary Storage and Material Handling
- Rugged High Capacity Billeting and Storage Shelters
- Asset Management Tracking
- Portable Rail/Maintenance and Wash Ramps

Procurement Vehicles. BANAIR products are available through:

BANAIR CORE COMPETENCY

- SAMS.gov
- DLA Tailored Logistics Programs:
- Special Operations Equipment (SOE)
- Maintenance Repair and Operations (MRO)
- Fire & Emergency Services Equipment



CLIENTS



MULTIPURPOSE MAINTENANCE, WAREHOUSE AND STORAGE SHELTER



DMTSS-100-40 DEPLOYABLE MULTI-PURPOSE TACTICAL SHELTER SUITE



- Higher R-Values
- Constant Thermal Resistance
- Noise Barrier
- Lower Energy Costs



- Better Resiliency to Wind & Hail
- Less Maintenance
- Longer Life Span
- Strongest Design



- Increased Stability in High Wind From All Angles
- Better Water & Snow Run Off
- Better Ventilation with integrated passive exhausting mechanism for heat built up

DMTSS-100-40

DIMENSIONAL OVERVIEW

FRONT elevation

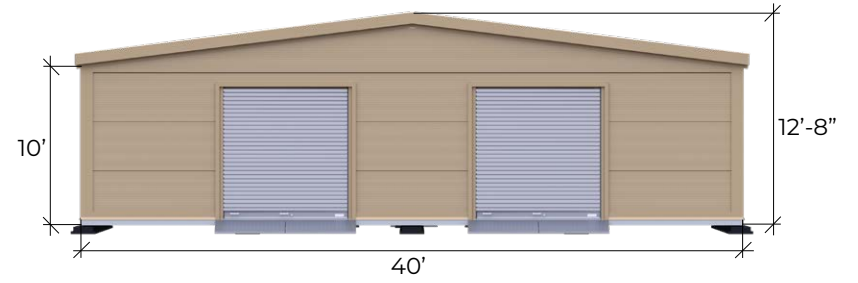

PLAN VIEW



DMTSS-100-40



ASSEMBLED EQUIPMENT. NOT CONSTRUCTION.

- Demountable & Relocatable Framework
- Assemble fast on-site
- Temporary Foundations
- Ships Inside ISO shipping containers



MADE FOR TOUGH ENVIRONMENTS

- Increased Stability in High Wind From All Angles
- Better Water & Snow Run Off
- Better Ventilation
- Corrosion Proof Storage



HARD WALL STRUCTURE

- Less Maintenance
- Longer Life Span
- Strongest Design
- Humidity controlled environment



EXTERIOR INSULATED CLADDING

- Higher R-Values
- Constant Thermal Resistance
- Noise Barrier
- Lower Energy Costs

DMTSS-100-40

OVERVIEW



EFFICIENT DEPLOYMENT

Complete system shipped inside ISO shipping containers.
Ready to assemble on site.
Qty TBC

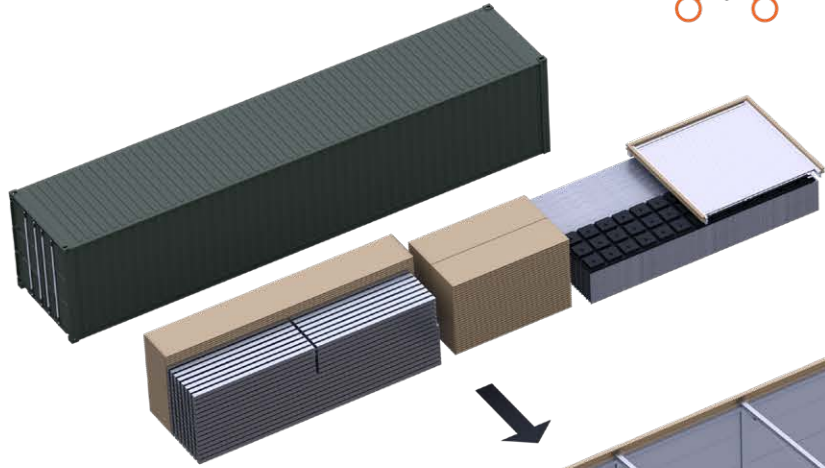

DEMOUNTABLE FRAMEWORK KIT

MAIN AREA CEILING TRUSS MOUNTED LED x6
• 53in
• 50 Watt
• Vapour Proof

ROLLER DOOR X2 EACH END
• 10ft x10ft

SHELTER GROUND MATTING
• Aluminum section

JACKPAD
• Reusable foundation system

CONCRETE BALLAST BLOCKS
• Temporary

DEMOUNTABLE GUTTERS
• 6in commercial grade

BANAIR WARRANTY

10 YEAR STRUCTURAL WARRANTY
3 YEAR FIXTURE AND FITTINGS
25+ EXPECTED SERVICE LIFE



BERTHER HardWall
Expeditionary Accommodation Suite

BERTHER HardWall

DIMENSIONAL OVERVIEW

PLAN VIEW

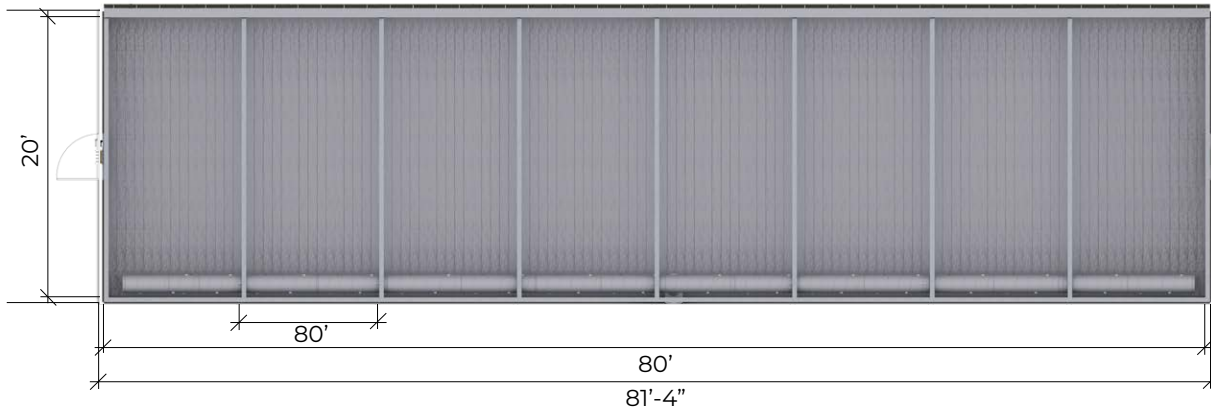

FRONT section



FRONT elevation

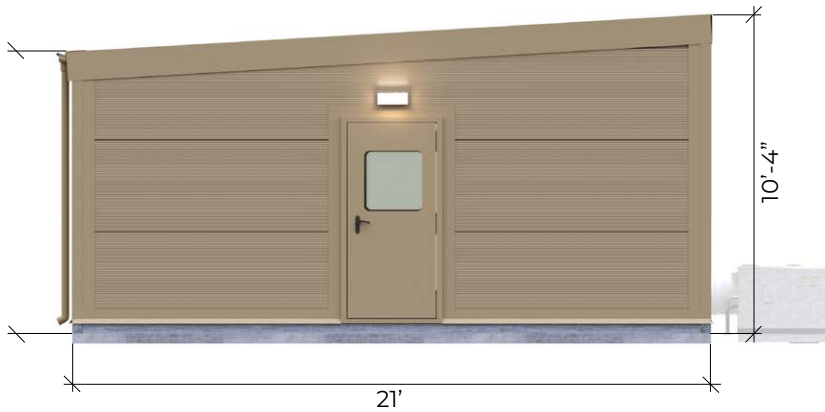

FRONT perspective





FABRIC OUTER

DMTSS-116-120

Deployable Multi-purpose Tactical Shelter Suite



HIP ROOF DESIGN

- Increased Stability in High Wind From All Angles
- Better Water & Snow Run Off
- Better Ventilation with integrated passive exhausting mechanism for heat built up



TENSION FABRIC TRUSS ROOF

- Better Resiliency to Wind & Hail
- Less Maintenance
- Longer Life Span
- Strongest Design



EXTERIOR INSULATED CLADDING

- Higher R-Values
- Constant Thermal Resistance
- Noise Barrier
- Lower Energy Costs



BANAIR HIGH CUBE CONTAINER

- Larger Volume 9.6ft tall
- Higher Vehicle Entrance Doors
- Better Heat Displacement
- Steel Floor Plate vs. Wood
- Upgraded anti-slip checker plate steel flooring vs. Standard container wood flooring



BANAIR GROUND MATTING

- Rapidly Deployable
- Multi-purpose
- Resilient to Ground Settling



RELOCATABLE LED LIGHTING

- Plug and Play
- No Heat or UV Emissions
- Energy Efficiency
- No Warm-up Delay
- Long Life
- Vapor and Moisture Tight

DMTSS-116-120

STRUCTURE

OPEN AREA 103' x 100'
 Flooring - Ground Matting 103' x 100' coverage



CONTAINER MOUNTED INDUSTRIAL FAN x8
 • 48in Diameter
 • 1.5 HP HP TEFC motor
 • 31,000 CFM
 • 28.7 DB



MAIN AREA CEILING TRUSS MOUNTED LED x8
 • 53in
 • 50 Watt
 • Vapor Proof
 • 5-yr Warranty



HVLS FAN x1
 • 24ft diameter
 • 2 hp motor

TOP CAP VENT with Lightning Protection

FABRIC INNER

FABRIC OUTER

FIRE WALL MOUNTED EXTINGUISHERS
 • Class ABC

SHELTER GROUND MATTING
 • Aluminum section

DEMOUNTABLE EXTERIOR INSULATED CLADDING

SOUND DAMPENING INTERIOR CLADDING FOR CADRE OFFICES ONLY

DEMOUNTABLE GUTTERS:
 • 6in commercial grade



ENTRANCE LIGHTS
 • LED
 • 45 Watt
 • 5,700 Lumens
 • Water & Vapor Tight

CARRIER HVAC SYSTEM* x4
 • 5-7 ton system
 • *Optional Upgrade

BANAIR WARRANTY

10 YEAR STRUCTURAL WARRANTY
 3 YEAR FIXTURE AND FITTINGS
 25+ EXPECTED SERVICE LIFE



EXIT LIGHTS
 • LED
 • Battery Back-up
 • 5-yr Warranty



SIDE MOUNTED CLIMATE CONTROL
 • 35,000 BTU
 • Coverage 2000-2500sq ft
 • Cooling/Heating

DMTSS-116-120

CONTAINER AREAS

FRONT



BACK

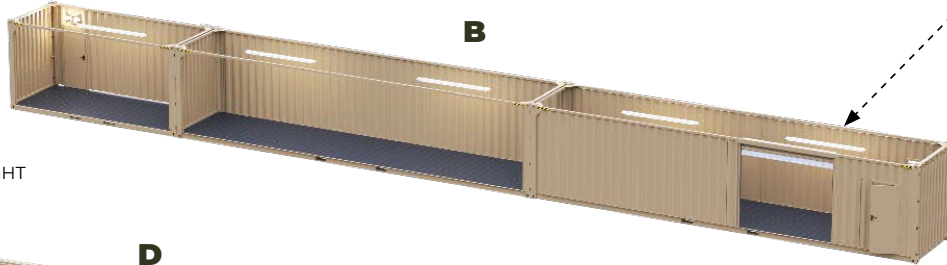

RIGHT

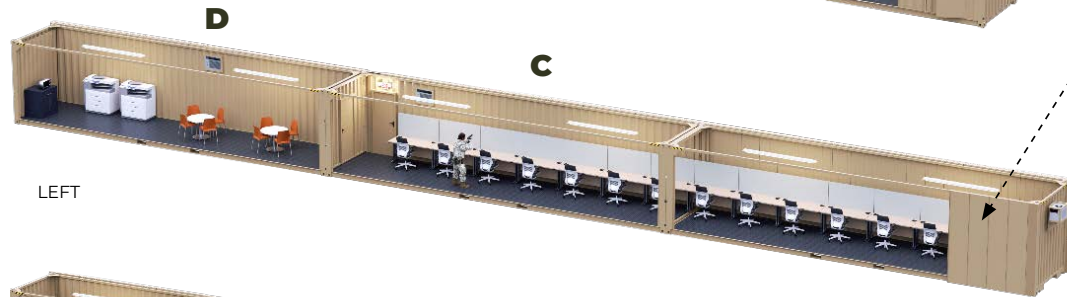

LEFT

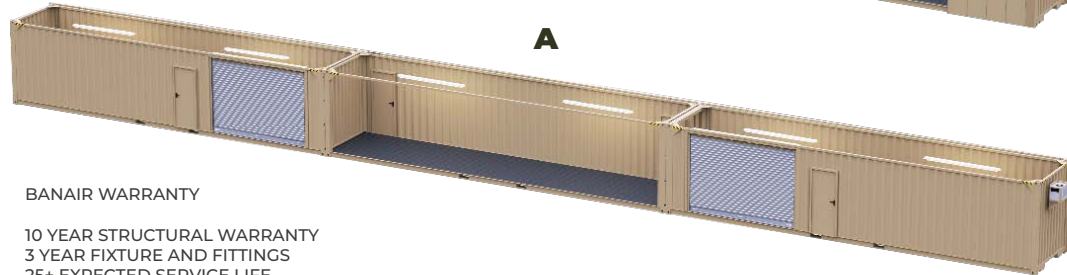

LED CONTAINER LIGHTING

- 8ft
- 54 Watt
- Vapor Tight
- 7020 Lumens

(2x per 40ft and 1x per 20ft container)

SOUND DAMPENING CLADDING FOR CADRE OFFICES ONLY

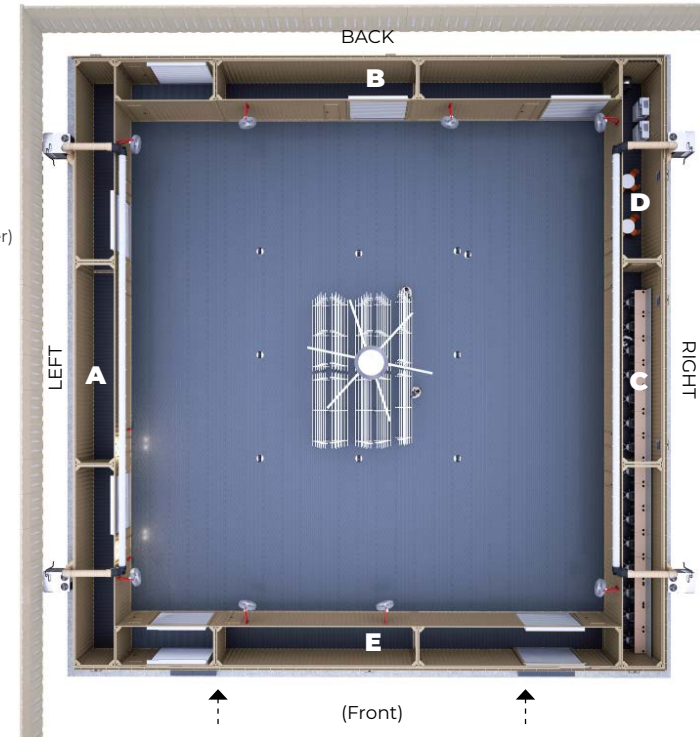

- A.** Qty3 40' High Cube with 6x personnel access + 2x 12ft wide roller doors / 2x Side mounted A/C Units
- B.** Qty1 40' High Cube + Qty1 20' High Cube with 3x personnel door + 2x 12ft wide roller doors
- C.** CADRE OFFICE SPACE: Qty2 40' High Cube to accommodate 15 people—5 feet of bench desk space per person along one wall / 2x Side mounted A/C Units / with 3x personnel door
- D.** BREAK ROOM / PRINTER: Qty1 40' High Cube with 1x personnel doors / x1 Side mounted A/C Unit.
- E.** Qty2 40' High Cube + Qty1 20' High Cube 6x personnel doors for access. 4x 12ft wide roller doors / 1x Side mounted A/C Unit

BANAIR WARRANTY

10 YEAR STRUCTURAL WARRANTY
3 YEAR FIXTURE AND FITTINGS
25+ EXPECTED SERVICE LIFE



INTERIOR WAREHOUSE STORAGE

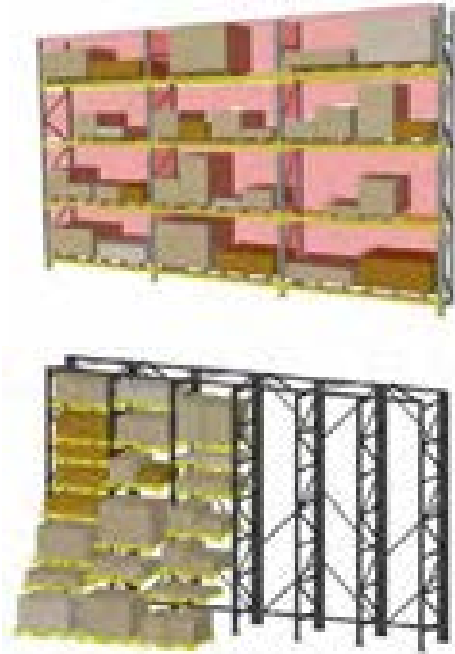

SAME AMOUNT OF STOCK AS TRADITIONAL RACK. 50% OF FOOTPRINT

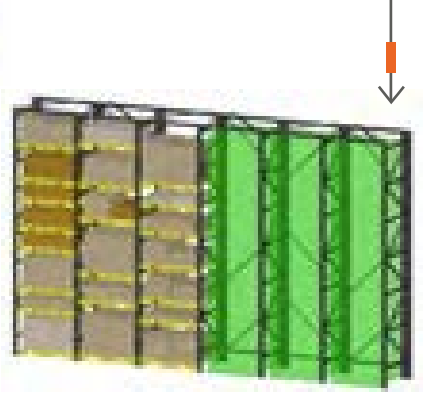

IARS™

INSTANTLY ADJUSTABLE RACK SYSTEM



ADJUSTABLE
BANAIR Pallets can be vertically positioned in 6in increments, and adjusted in moments without inventory

SPACE SAVING
The original and best way to optimize your available warehouse cube: eliminate stored air. BANAIR.

RACKMEZZ
IARS supported Multi-level level storage for small part bins / roll out drawers and heavy duty shelves.

MOBILE OPTIONS
Intergrate with mobile bases to further maximise warehouse space



CARGORACK INTERIOR

INTERIOR FIXED OR MOBILE CARGO OPTIONS



HIGH-DENSITY RACK
BANAIR systems compatibility



SPACE SAVING
The original and best way to optimize your available warehouse cube: eliminate stored air. BANAIR.

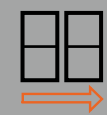

MOBILE OPTIONS
Intergrate with mobile bases to further maximise warehouse space



CARGO CUBER

FREE STANDING STORAGE CUBE FOR HEAVY DUTY CARGO

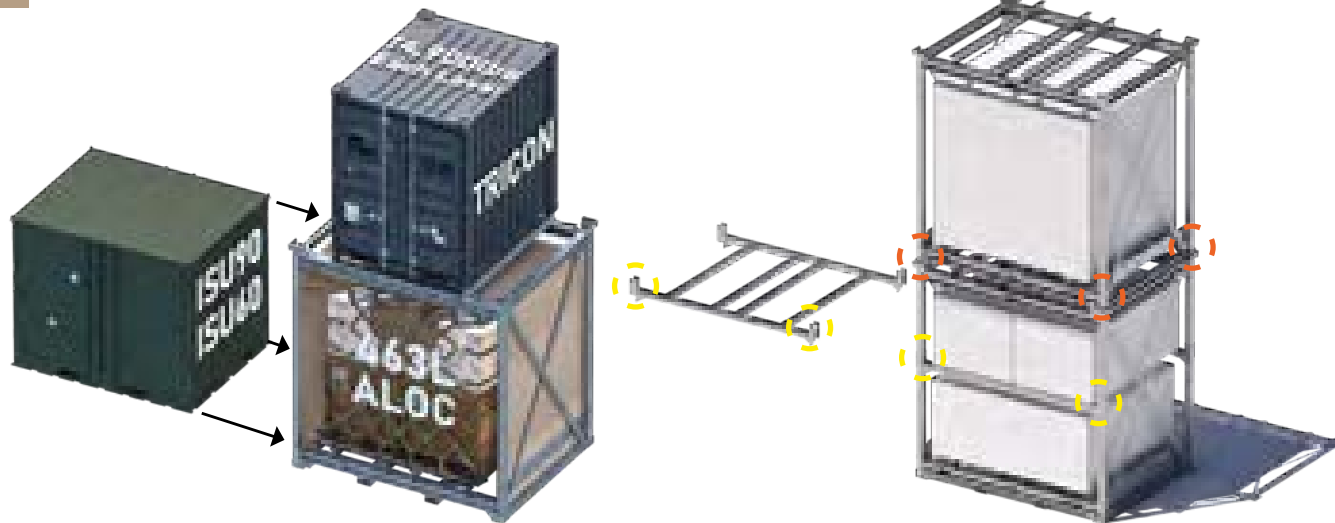

INTERNAL USEABLE
120in (W) X 93in (D) X 100.5in (H)

EXTERNAL
129.125in (W) X 102in (D) X 126.75in (H)

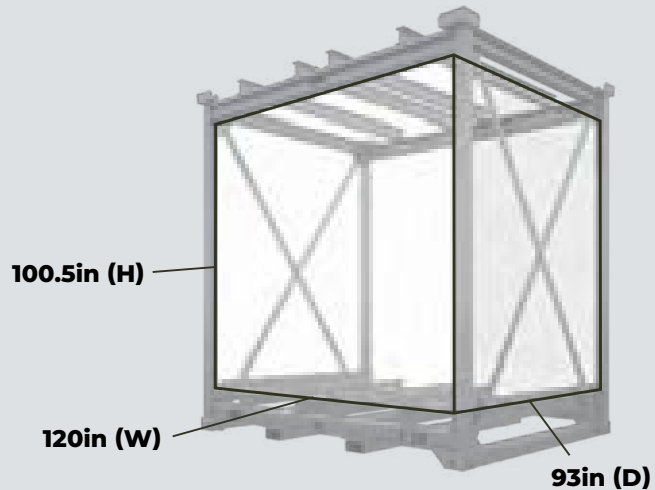

VERSATILE
Designed for 14,900lbs
463L (ALOC) / ISU90 / TRICON



STACKABLE
Custom steel lugs engage with bottom ISO corner castors



INTERNAL SHELF
can be fitted at three different heights to allow for crates, cargo, pallets, boxes

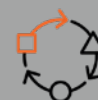

RECONFIGURABLE
Change layouts on the fly. Adapt to suit your changing mission.

CUBER 44"

CUBER 62"



CUBER 83"

CUBER 100"

Height same as ISO BICON



WEIGHT CAPACITY
5 SHORT TONS (10,000 lbs)



WEIGHT CAPACITY
5 SHORT TONS (10,000 lbs)



WEIGHT CAPACITY
5 SHORT TONS (10,000 lbs)



WEIGHT CAPACITY
5 SHORT TONS (10,000 lbs)



ROLLING STACK

HIGH DENSITY ROLLING STOCK CRATES



STACKABLE
Custom steel lugs engage with bottom ISO corner castors

 **MOVEABLE**
Compatible with all major forklift manufacturers and types

 **MOBILE OPTIONS**
Intergrate with mobile bases to further maximise warehouse space



CARGORACK

EXTERIOR STORAGE SOLUTIONS FOR MILITARY CARGO & BULK



- › 463L / ISU90
- › TRICON
- › QUADCON
- › BICON
- › CRATES
- › US GOVT PALLETS



INTEGRATED ROOF

Optional roof systems engineered to take snow / wind loads for challenging environments

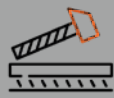

DURABLE

Designed tough for demanding workplace environments. Built to last. Lifetime Warranty.



REPAIRABLE

Impact damage, dents & scrapes can all be repaired on 100% of BANAIR equipment, protecting your workforce & long-term

SSA Yard, Mihail Kogălniceanu, Romania



INTEGRATED ROOF
Roof system engineered to protect products from challenging weather conditons



OPTIMIZED
Designed / sized to meet specific product needs



GENERATOR

LAYDOWN CURTAIN CARGO RACK

ROTARY BLADE

SPECIALIZED CARGO RACK FOR ROTARY BLADES

Helicopter Blades
7.8m (25'-5") Long
(6m Long Cates Shown)

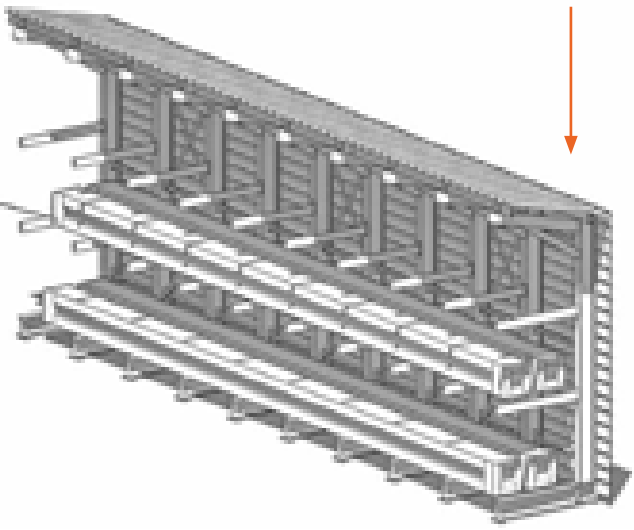

OPTIMIZED
Designed / sized to meet specific product needs



SPACE SAVING
The original and best way to optimize your available warehouse cube: eliminate stored air. BANAIR.





DEPLOYABLE
By AIR, LAND and SEA
20ft, BICON, TIRCON
and QUADCON



FULL ACCESS
Get to the part you need,
when you need it. FAST



POL STORAGE

HAZMAT CARGO RACK

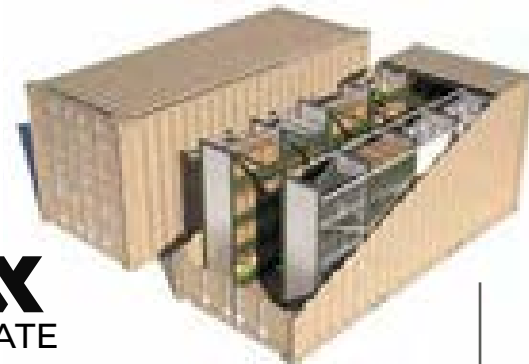

RACKBOX

STORE / DEPLOY / OPERATE



OPTIMIZED
Designed / sized to meet
specific product needs



ENCLOSED
Roof & curtain system to
protect products from
challenging weather conditons



SUPERIOR LIGHT & TRUE PORTABILITY
95K LUMEN



FACTS B1430MIL, B1600MIL

Weight:	43kg, 47kg
Max Height:	8.2m
Width:	30cm
Length:	154, 164
Power:	400W, 600W
IP Code:	IP65
Voltage:	110-240VAC

BASELIGHT

NEXT GENERATION LED MOBILE LIGHT TOWER



MOVABLE & LIGHTWEIGHT



UNRIVALLED PERFORMANCE



DEPLOYABLE

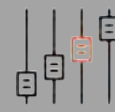

ADJUSTABLE



RUGGED



STORAGE CASE STUDIES

Isometric Layout View

Bldg 9817 JSSD-K Warehouse

ISOMETRIC view

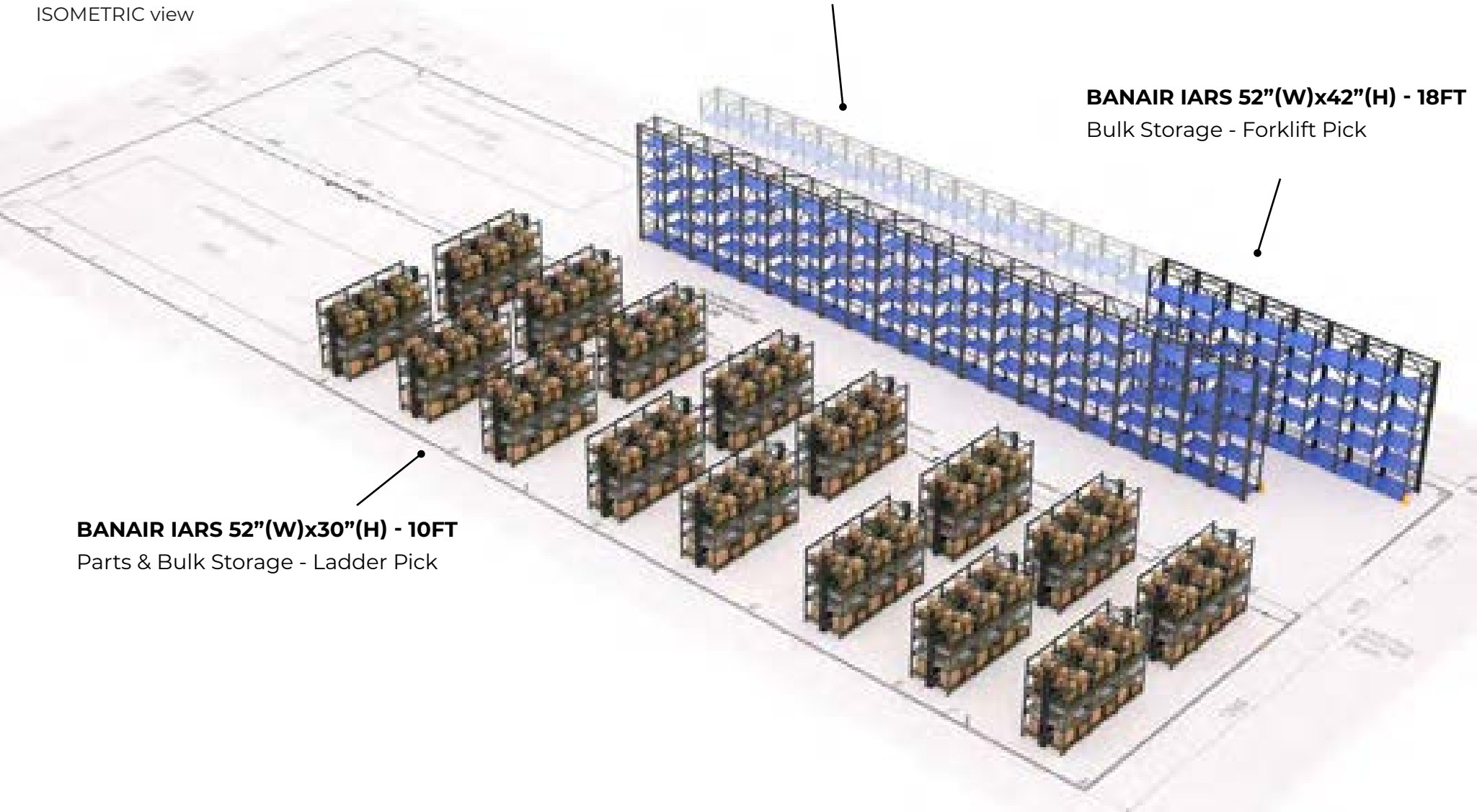

EXISTING RACKING

BANAIR IARS 52''(W)x42''(H) - 18FT
Bulk Storage - Forklift Pick

BANAIR IARS 52''(W)x30''(H) - 10FT
Parts & Bulk Storage - Ladder Pick

Isometric View - R1 to R3

Bldg 9817 JSSD-K Warehouse

x29 (52" x 42") Bays at 18ft (H)
x145 (52" x 42") BAN-AIR Pallets SWL 2500Lbs

ISOMETRIC view

Front Elevation

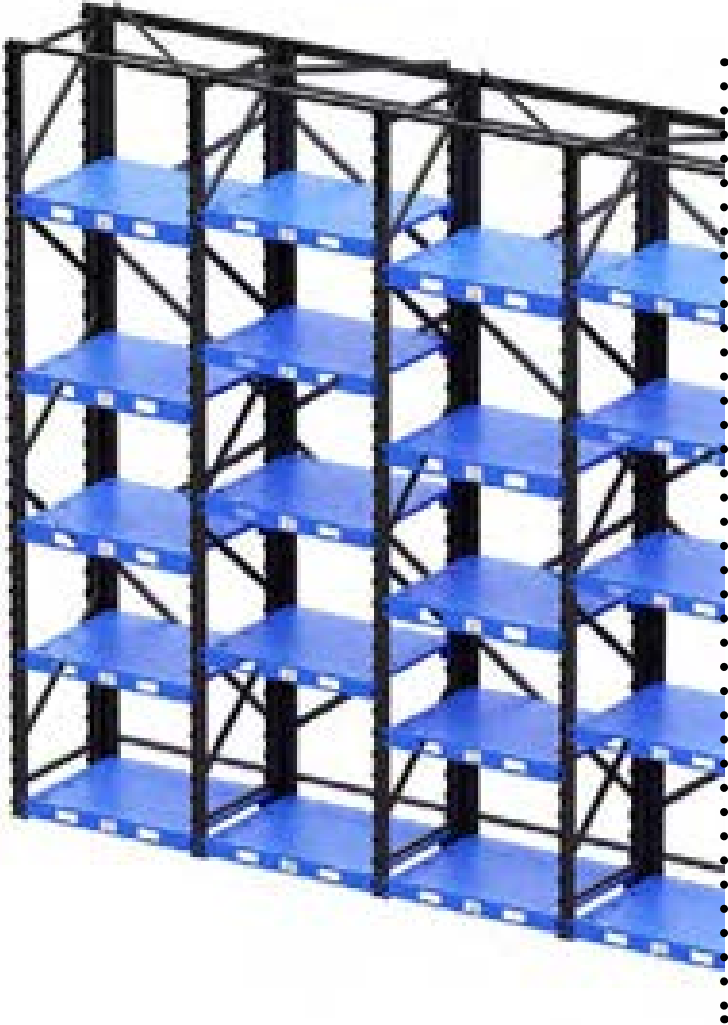
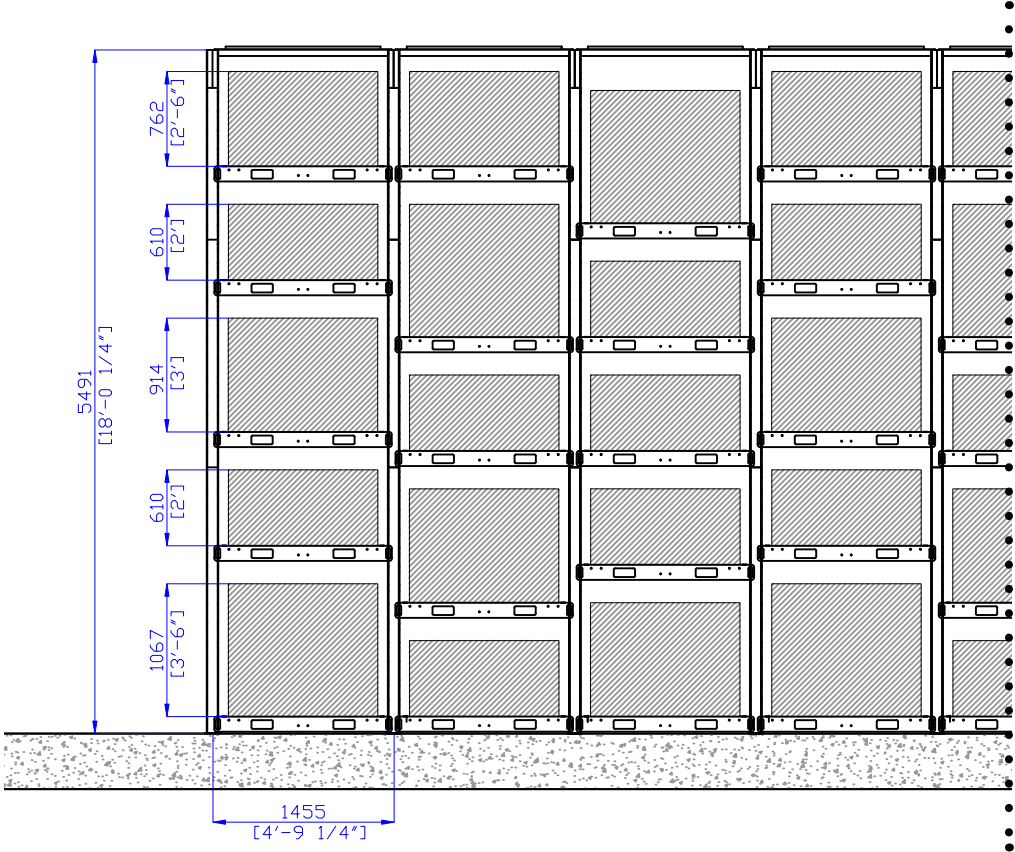

MAX LOAD PER PALLET 2500 LBS.

Isometric View - R3 to R34

Bldg 9817 JSSD-K Warehouse

- x96 (52" x 30") Bays at 10ft (H)
- x192 Pull Out Drawers
- x288 Bulk Storage Fixed Shelf

ISOMETRIC view

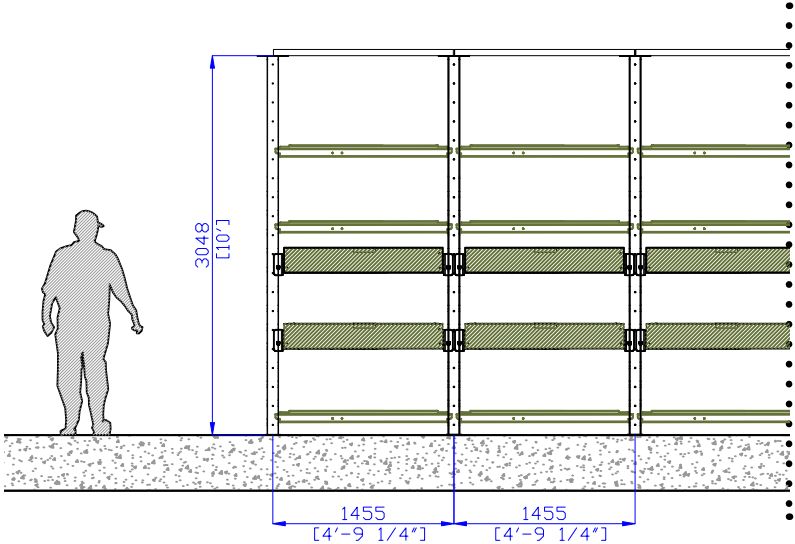

BANAIR DRAWER INTERNAL SIZE 48" W 30" D

MAX LOAD PER DRAWER 400 LBS.

Play View

6th AMXS Alternate Equipment Warehouse

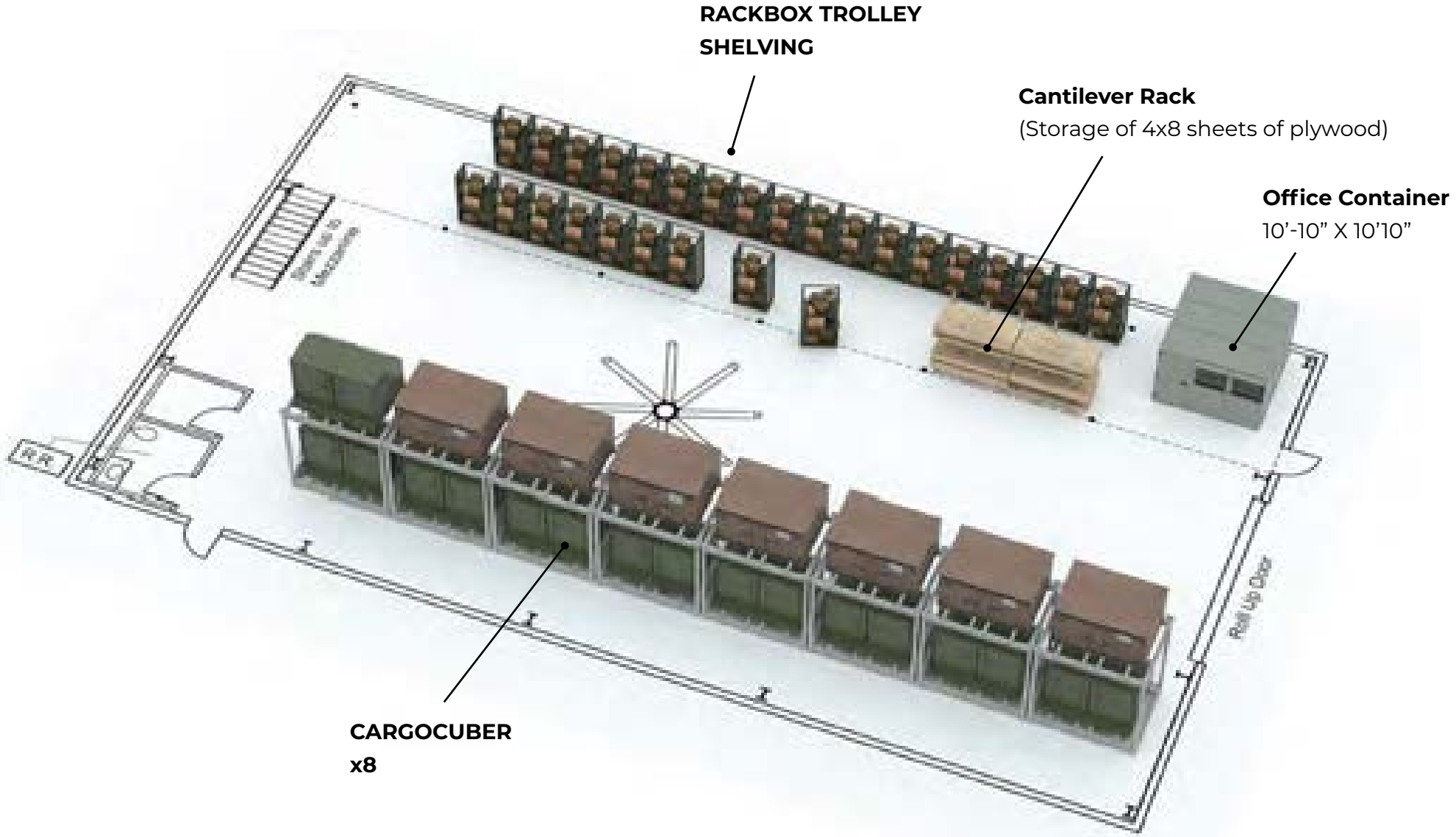

Row 1 / CargoCuber x8

ISU70 & ISU ROLLER storage - Total x16 positions



ISU ROLLER KIT

104" (L) X 76.5" (D) X 53" (H)

ISU70

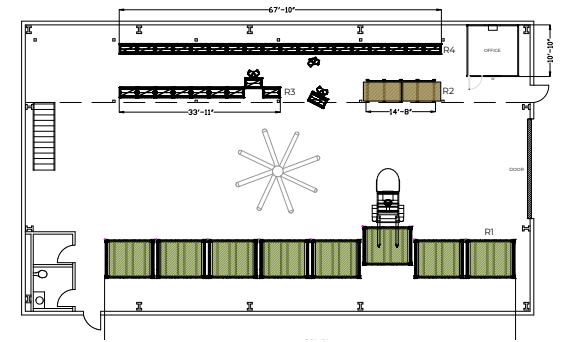

Designed for:

- 463L (ALOC) / ISU containers / TRICON
- Any load upto 120"x93"x100.5"(WxDxH)

14,900lbs Capacity Each Level

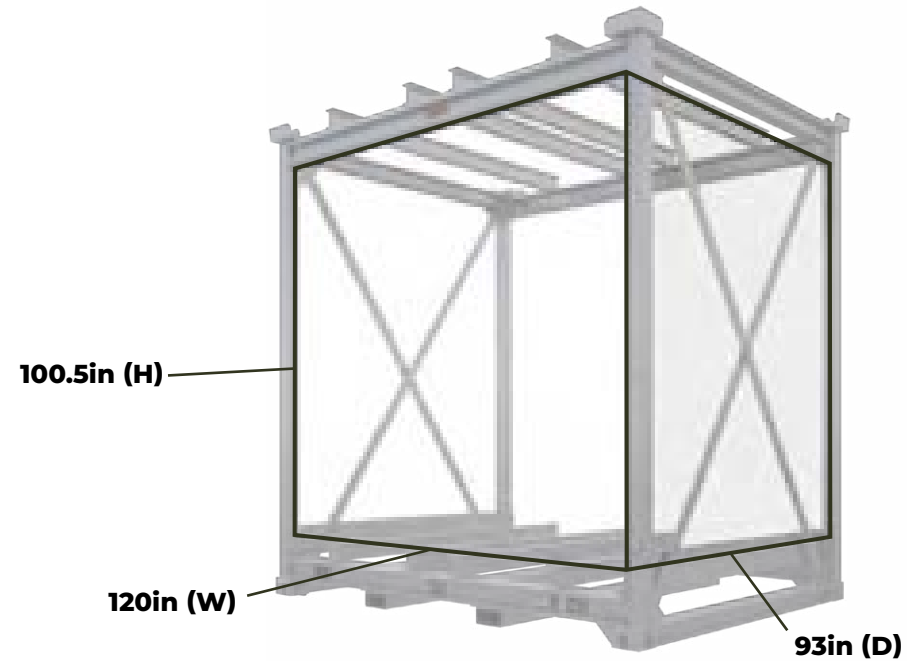

MOVEABLE

Compatible with all major forklift manufacturers and types

INTERNAL USEABLE

120in (W) X 93in (D) X 100.5in (H)

EXTERNAL

129.125in (W) X 102in (D) X 126.75in (H)

Row 3&4 / RACKBOX TROLLEY SHELVING

x27 (42" x 30") Bays

x81 Bulk Storage Adjustable Shelves

ISOMETRIC view

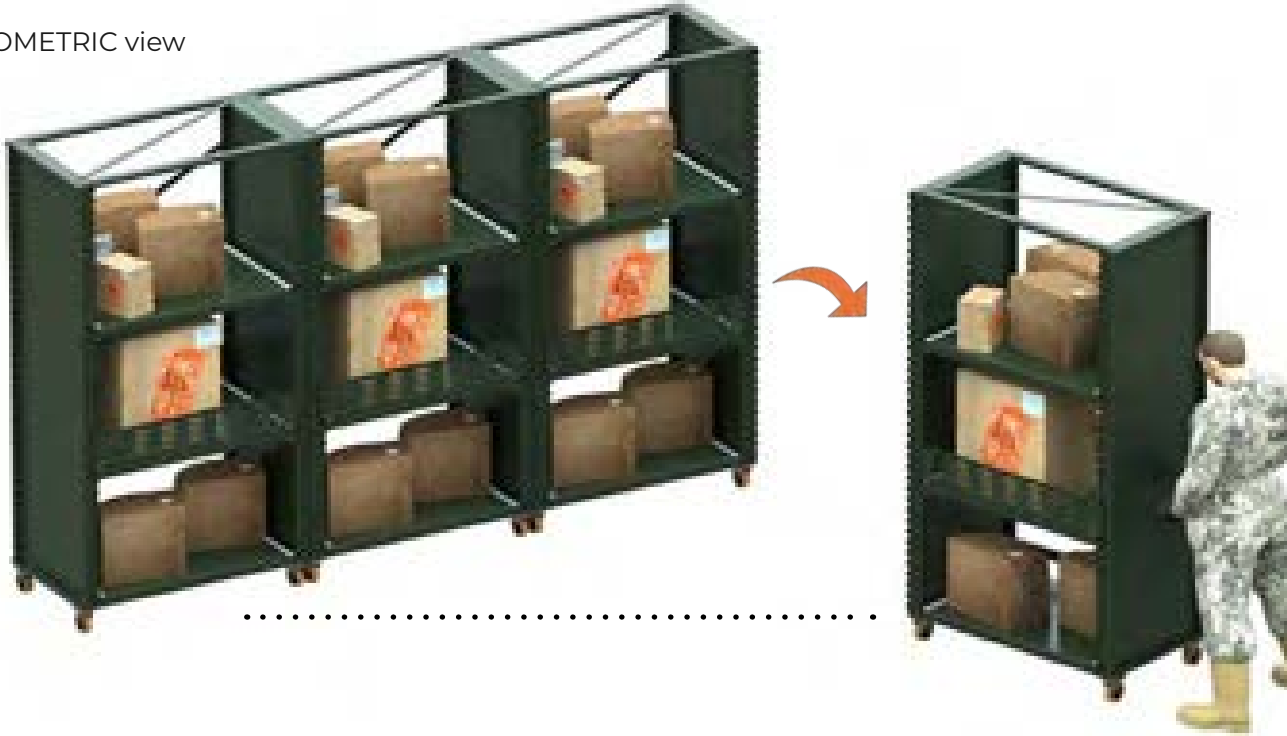

RACKBOX SHELF INTERNAL SIZE 42" W 30" D 24" H

MAX LOAD PER DRAWER 400 LBS.

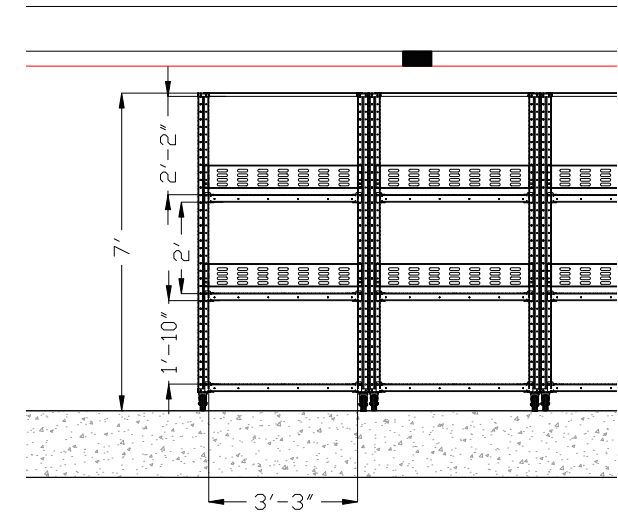
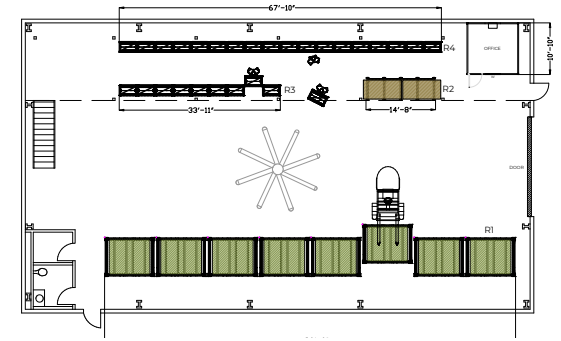

RECONFIGURABLE

Each trolley is on castors allowing reconfigurable layouts.



ADJUSTABLE

Shelves easily adjust in 2in increments to allow RACKBOX to adapt as needed



Ali Al Salem AB, Kuwait



BANAIR UNIVERSAL CARGO RACK

Overall System (Row 1-10)
110 bays total, 2 platforms high
Approx 8m (26') Forklift Space

Total 463L / ISU90 positions - Qty 220



ROLLINGSTACK

HIGH DENSITY ROLLING STOCK CRATES

SPACE SAVING



ADAPTABLE



FORKLIFT
OPERABLE



IN-HOUSE DESIGN
& ENGINEERING



READINESS



DEPLOYABLE



BANAIR

©2021 Elements Industrial Storage Ltd. All rights reserved.
No unauthorized copying or distribution without prior permission

OPTION 4
 MOBILE CRATES x720
 FIXED CRATES x76



RS170.88.52-8K x168
 x168 MOBILE



RS196.110.76-8K x38
 x38 FIXED



RS170.88.84-8K x552
 x480 MOBILE



RS196.110.100-8K x38
 x38 FIXED

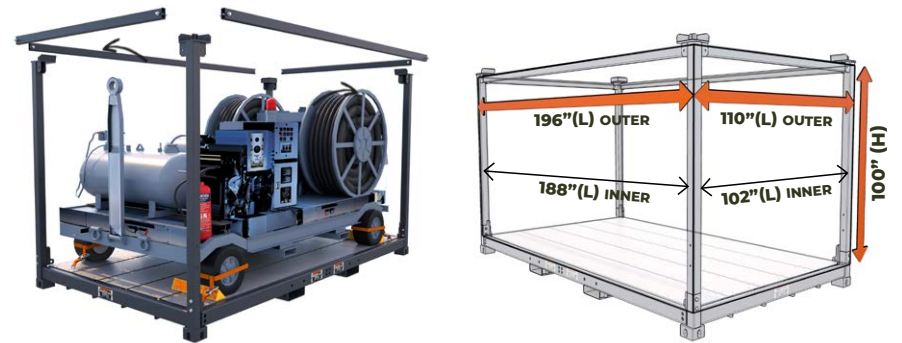

ISU90 RACK

PAD 17,23,24



TOTAL ISU90 POSITIONS PER SYSTEM - x84

42 bays total, 2 platforms high
(With Inspection Walkways & Rack Supported Fixed Roof)



Front Elevation

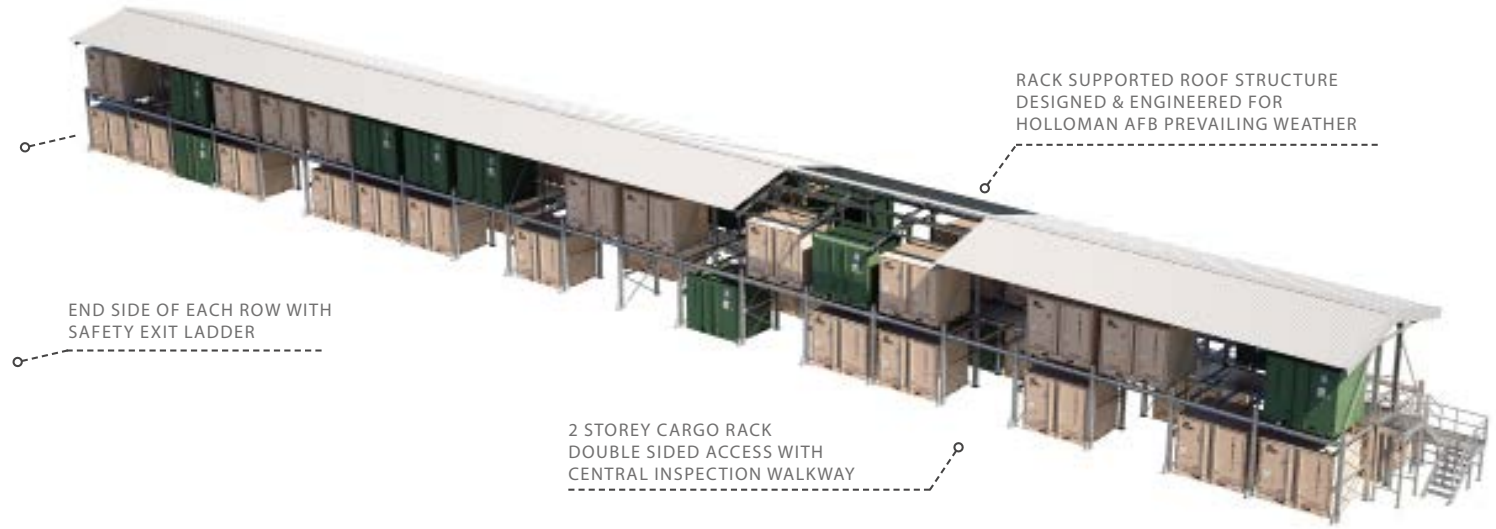
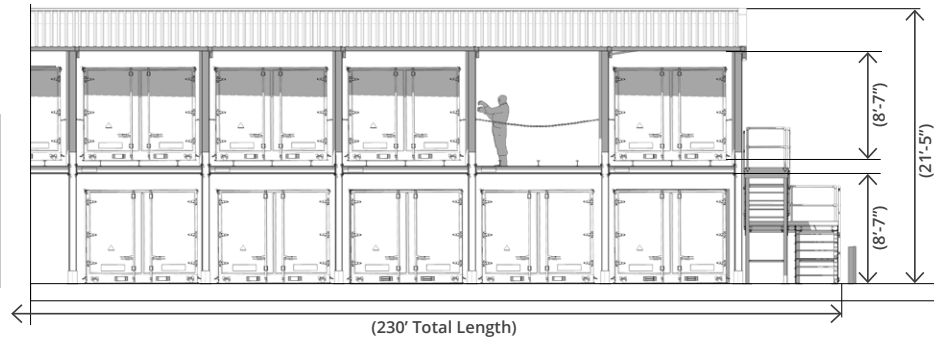

RACKMEZZ

STAIR KITS / WALKWAYS

INTEGRATED ACCESSORIES:
SMALL PARTS BINS

ROLL-OUT SHELVES &
HEAVY DUTY DRAWERS





MANUFACTURER

WWW.BAN-AIR.COM

SALES@BAN-AIR.COM

+44 121 401 1122 (EUROPE)

+1 919 753 8429 (USA)